

FOR OFFICIAL USE



National
Qualifications
2014

Mark

X735/75/01

**Graphic
Communication**

THURSDAY, 8 MAY

1:00 PM – 2:30 PM



* X 7 3 5 7 5 0 1 *

Fill in these boxes and read what is printed below.

Full name of centre

Town

Forename(s)

Surname

Number of seat

Date of birth

Day

Month

Year

Scottish candidate number

Total marks — 60

Attempt ALL questions.

Write your answers clearly in the spaces provided in this booklet. Additional space for answers is provided at the end of this booklet. If you use this space you must clearly identify the question number you are attempting.

All dimensions are in mm.

All technical sketches and drawings use third angle projection.

You may use rulers, compasses or trammels for measuring.

Use blue or black ink.

Before leaving the examination room you must give this booklet to the Invigilator; if you do not, you may lose all the marks for this paper.



* X 7 3 5 7 5 0 1 0 1 *

1. A graphic designer for a football magazine is commissioned to design a chart or graph. It should display the information in the table below in a visually stimulating and easy to read manner.

English Premier League players' average annual basic wages from 2000–2010	
<i>Season</i>	<i>Average annual basic wage</i>
2000–2001	£451,274
2001–2002	£566,932
2002–2003	£611,068
2003–2004	£651,222
2004–2005	£630,355
2005–2006	£685,748
2006–2007	£778,103
2007–2008	£960,377
2008–2009	£1,066,391
2009–2010	£1,162,350

- (a) State the most suitable type of chart or graph to use when presenting the information in the table above. 1

- (b) Explain one reason for using this type of chart or graph. 1

Total marks 2



* X 7 3 5 7 5 0 1 0 2 *

2. An advertising company has produced a promotional graphic to be used at a sports stadium. The graphic will be placed on the advertising boards around the pitch.

The initial layout is shown below.



Layout 1

- (a) State **one** instance where **harmony** has been used in **layout 1**. 1

The graphic artist has decided to change the background colour to violet as shown below.

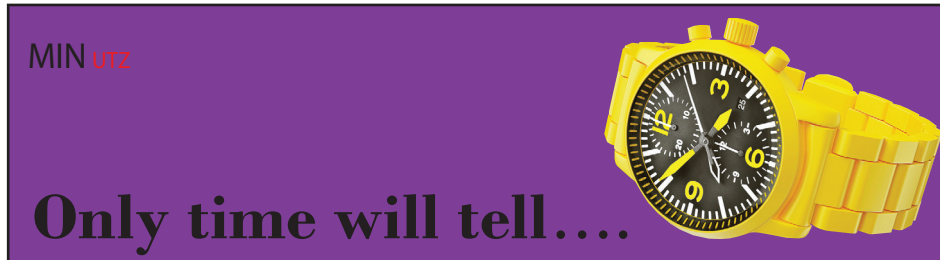

Layout 2

- (b) (i) Explain a reason for changing the background colour to violet. 1

- (ii) State whether violet is an advancing or receding colour. 1

- (iii) Describe the effect the violet background colour has on the watch. 1



2. (continued)

The graphic artist wants to change the shade of violet used for the background colour as shown below.



Layout 3

(c) Explain how to create a **shade** of violet. 1

(d) Describe **two** examples of **unity** in **layout 3**. 2

Method 1 _____

Method 2 _____

(e) Describe how the desktop publishing technique '**bleed**' has been used in **layout 3**. 1

(f) Describe how the desktop publishing technique '**reverse**' has been used in **layout 3**. 1

MARKS

DO NOT
WRITE IN
THIS
MARGIN

2. (continued)

The owners of the sports stadium decide to show the advert on their electronic advertising boards.

(g) State **two** environmental benefits of advertising this way.

2

Benefit 1 _____

Benefit 2 _____

Total marks 11

[Turn over



* X 7 3 5 7 5 0 1 0 5 *

3. Two stages in the production of a 3D CAD model of a headphone connector are shown below.

Stage 1

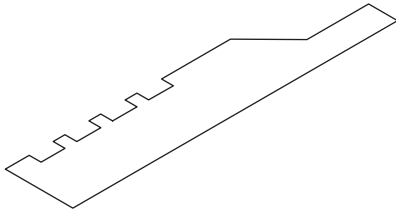

Before

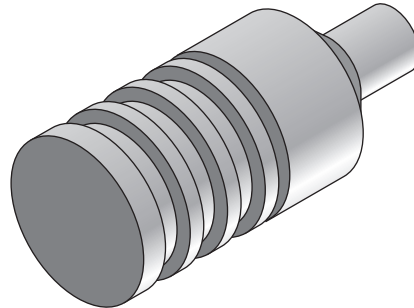

After

Stage 2

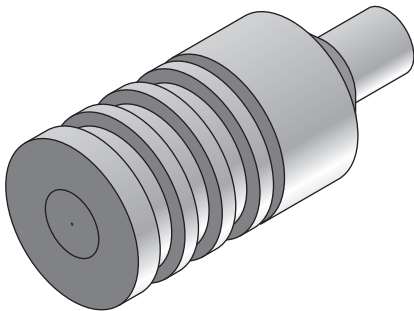

Before

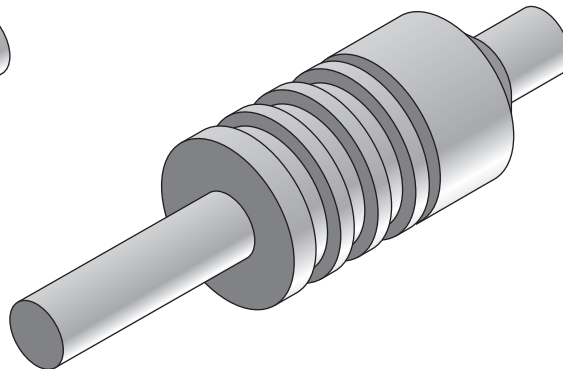

After

- (a) State the name of the 3D modelling feature which has been used in Stage 1.

1

- (b) State the name of the 3D modelling feature which has been used in Stage 2.

1

Total marks 2



4. Two building symbols which are commonly found in sectional views of buildings are shown below.

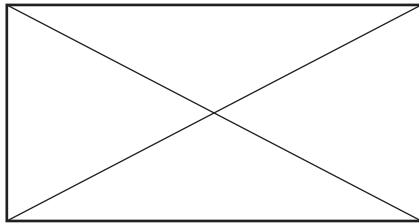

Symbol 1

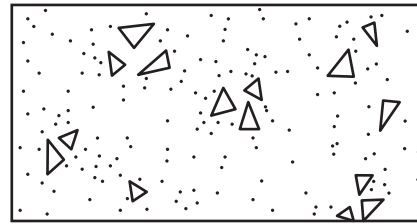

Symbol 2

State the name of:

2

Symbol 1 _____

Symbol 2 _____

5. A 3D CAD model of a new craft knife design is shown below.

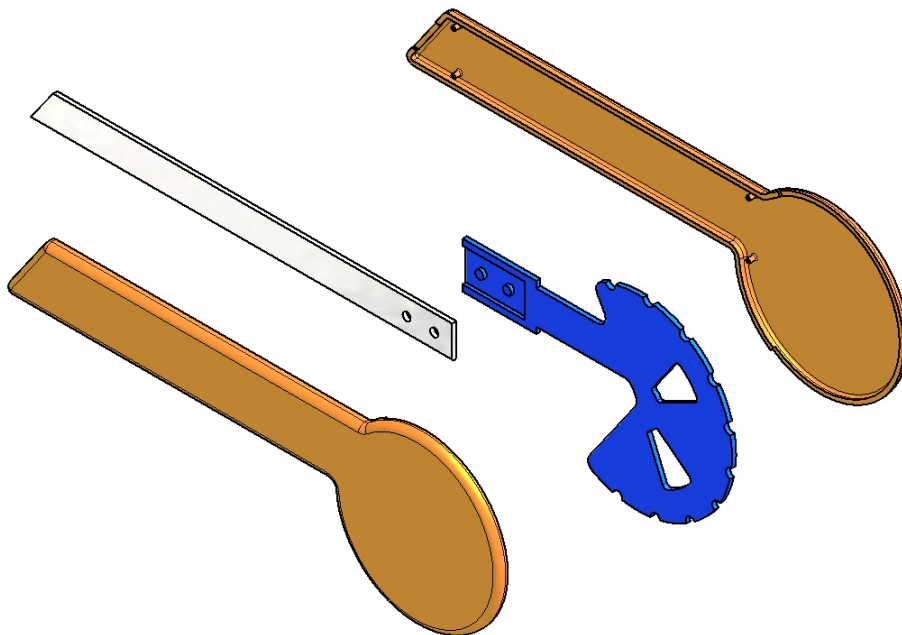

State **three** disadvantages to a design company of using 3D CAD modelling instead of traditional manual modelling.

3

1 _____

2 _____

3 _____



6. A variety of views of a child's wooden toy train are shown below.

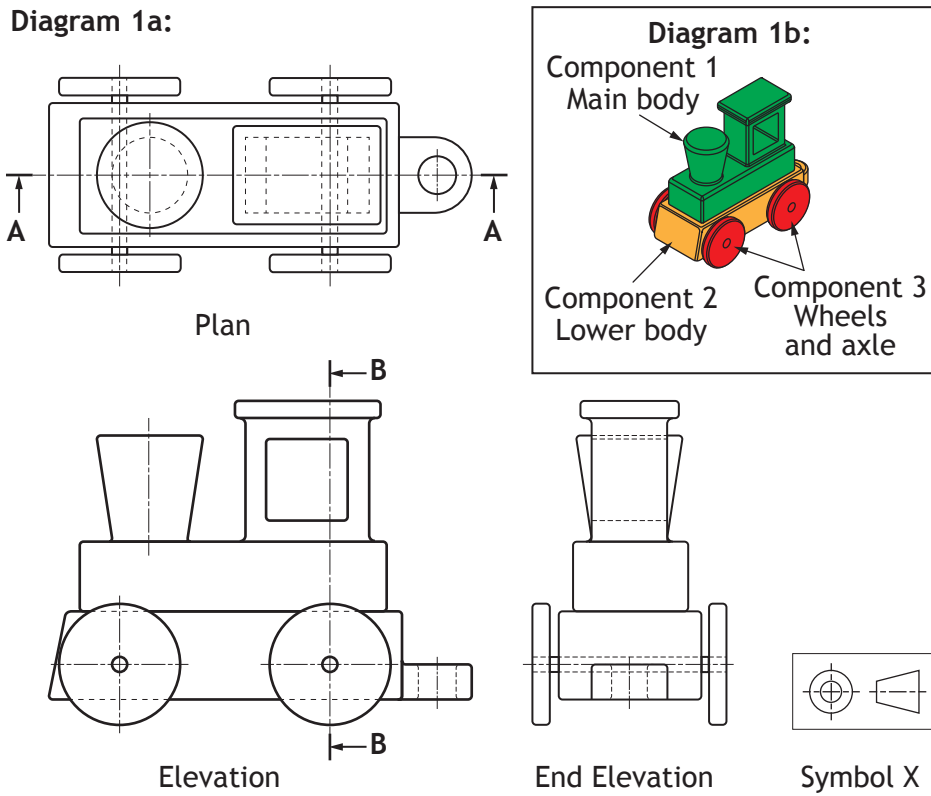

(a) State the name of the type of drawing shown in Diagram 1a. 1

(b) State the name of Symbol X in Diagram 1a. 1

(c) Describe the purpose of Symbol X. 1

6. (continued)

MARKS DO NOT WRITE IN THIS MARGIN

Four potential Sectional Elevations of the toy train views are shown below.

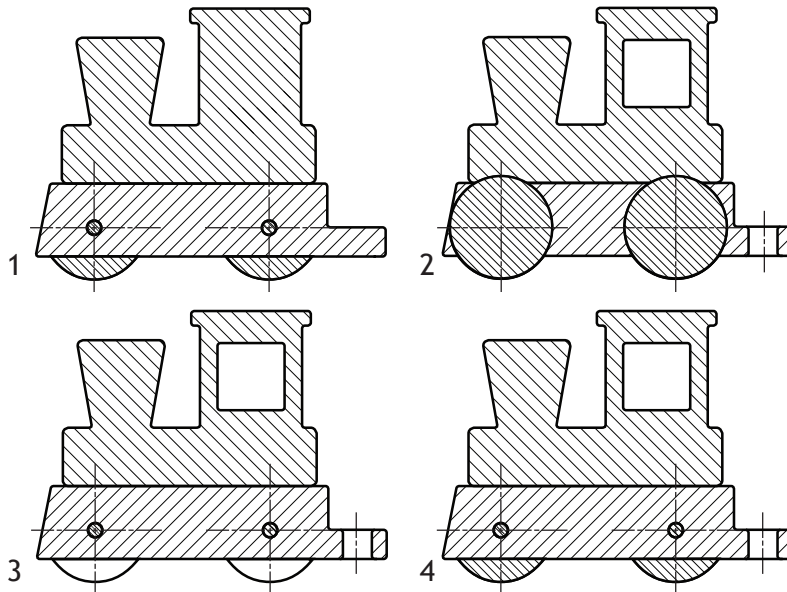

Diagram 2: Sectional Elevations on A–A

- (d) State, with reference to Diagram 1a and Diagram 2, the correct Sectional Elevation on A–A.

1

Four potential Sectional End Elevations of the toy train views are shown below

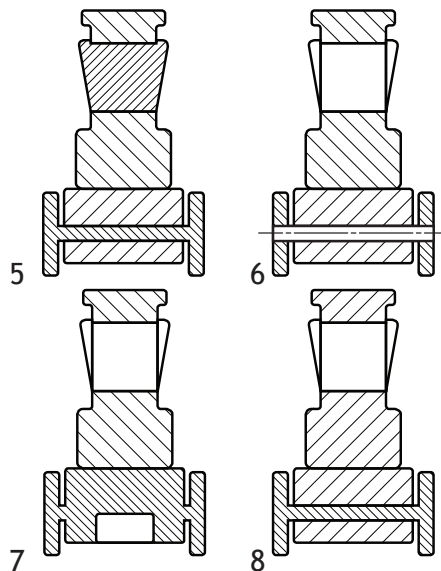

Diagram 3: Sectional End Elevations on B–B

- (e) State, with reference to Diagram 1a and Diagram 3, the correct Sectional End Elevation on B–B.

1



6. (continued)

Two pictorial views of the toy train are shown below.

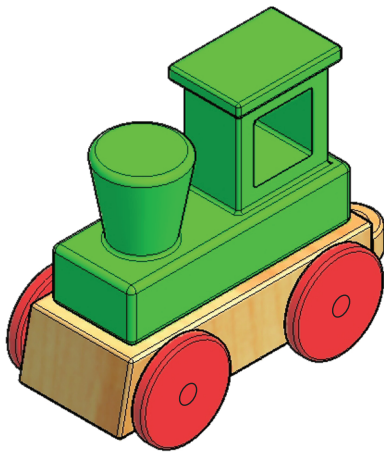

View 1

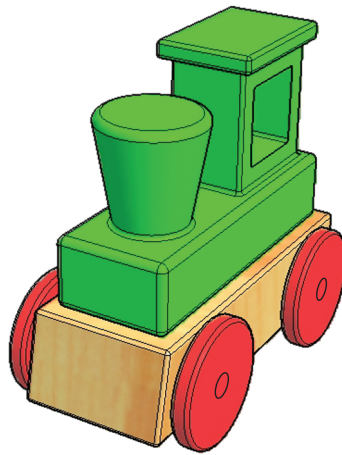

View 2

(f) State the name of the pictorial view shown at:

(i) View 1

1

(ii) View 2

1

(g) State the name of another **two** types of pictorial views which would be suitable to show the train.

2

Pictorial type 1

Pictorial type 2

6. (continued)

A partial End Elevation complete with relevant dimensions (Diagram 4a) of the toy train is shown below. An End Elevation of the train track is shown (Diagram 4b).

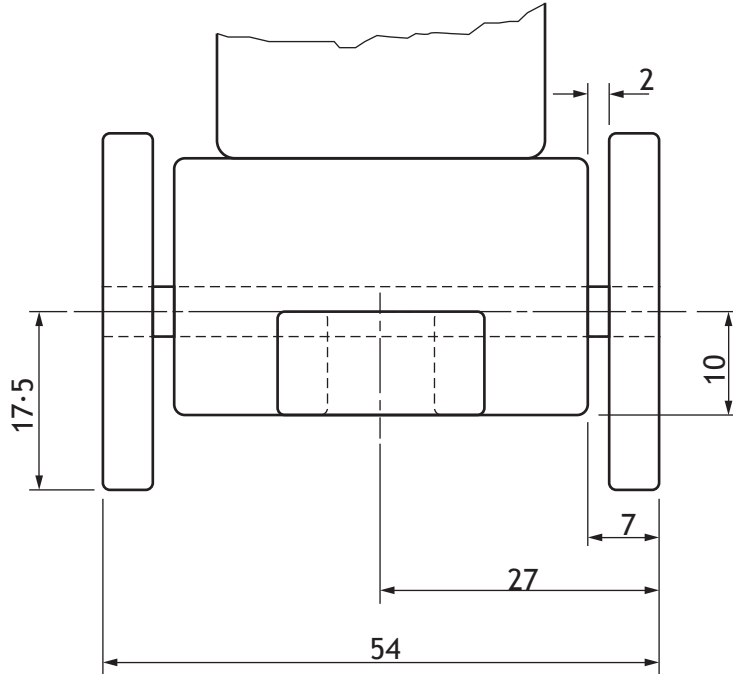
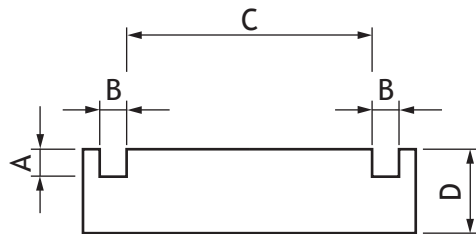

Diagram 4a: Dimensioned Partial End Elevation of the toy train



Track End Elevation

Diagram 4b: End Elevation of train track

(h) State, with reference to Diagram 4a and 4b, a dimension for:

- (i) A _____ 1
- (ii) B _____ 1
- (iii) C _____ 1
- (iv) D _____ 1



6. (continued)

The train track can be made up with the four different track tiles shown in Diagram 5.

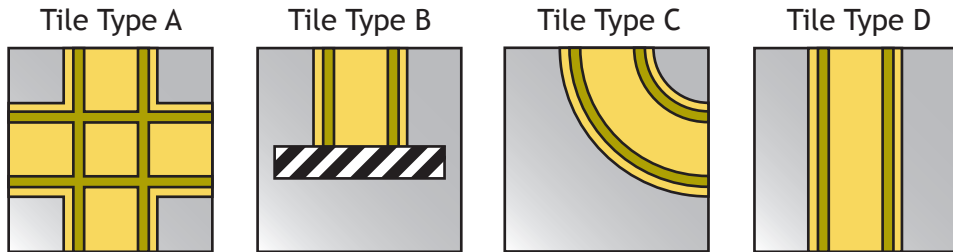

Diagram 5: Example Track Tiles

Diagram 6 shows a completed track layout using a minimum number of tiles.

Number of type A tiles:	<input type="text" value="0"/>	
Number of type B tiles:	<input type="text" value="0"/>	
Number of type C tiles:	<input type="text" value="1"/>	
Number of type D tiles:	<input type="text" value="3"/>	

Diagram 6: Completed Track Layout

6. (continued)

Three incomplete track designs are shown below.

- (i) State, with reference to Diagrams 5 and 6, the minimum number of each type of track tile required for each track design. All open ends must be blocked off.

Tiles may be rotated.

- (i) Track design 1:

4

Number of type A tiles:

Number of type B tiles:

Number of type C tiles:

Number of type D tiles:

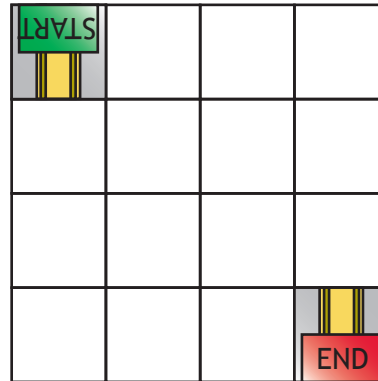

- (ii) Track design 2:

4

Number of type A tiles:

Number of type B tiles:

Number of type C tiles:

Number of type D tiles:

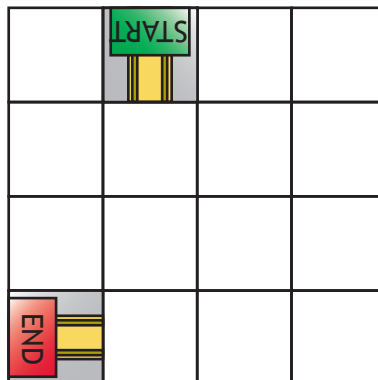

- (iii) Track design 3 (your track must reach both END points):

4

Number of type A tiles:

Number of type B tiles:

Number of type C tiles:

Number of type D tiles:

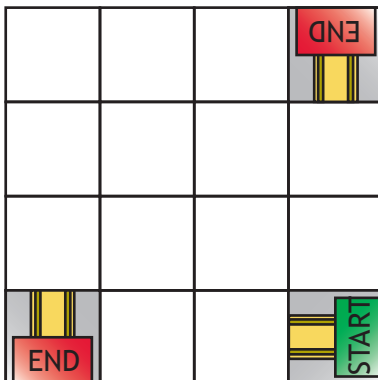

Total marks 25



* X 7 3 5 7 5 0 1 1 3 *

MARKS

DO NOT
WRITE IN
THIS
MARGIN

7. A door handle and door plate were designed using 3D modelling software. An exploded isometric view of the door handle and door plate is shown below.

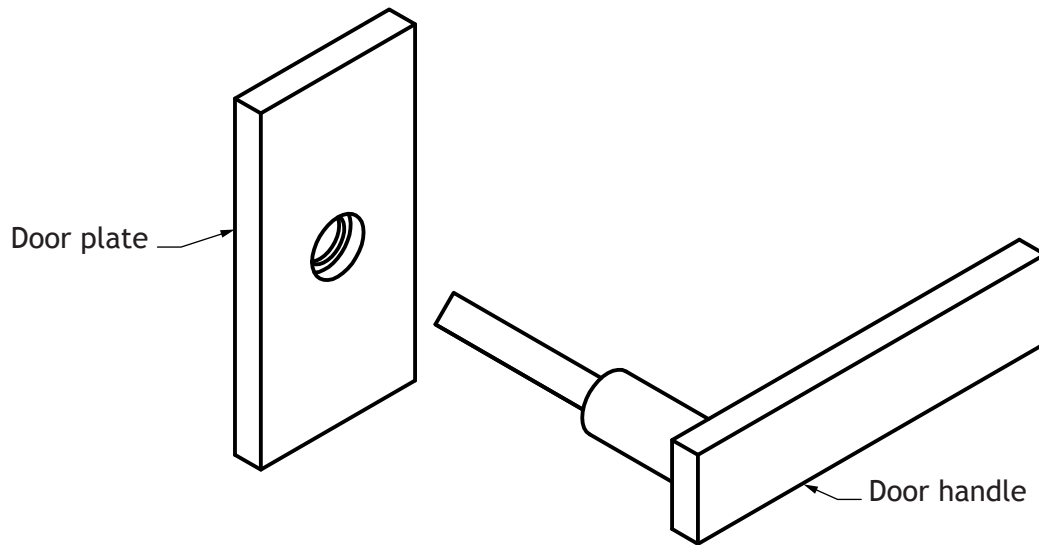

A preliminary orthographic sketch of the door handle (not to scale) is shown below.

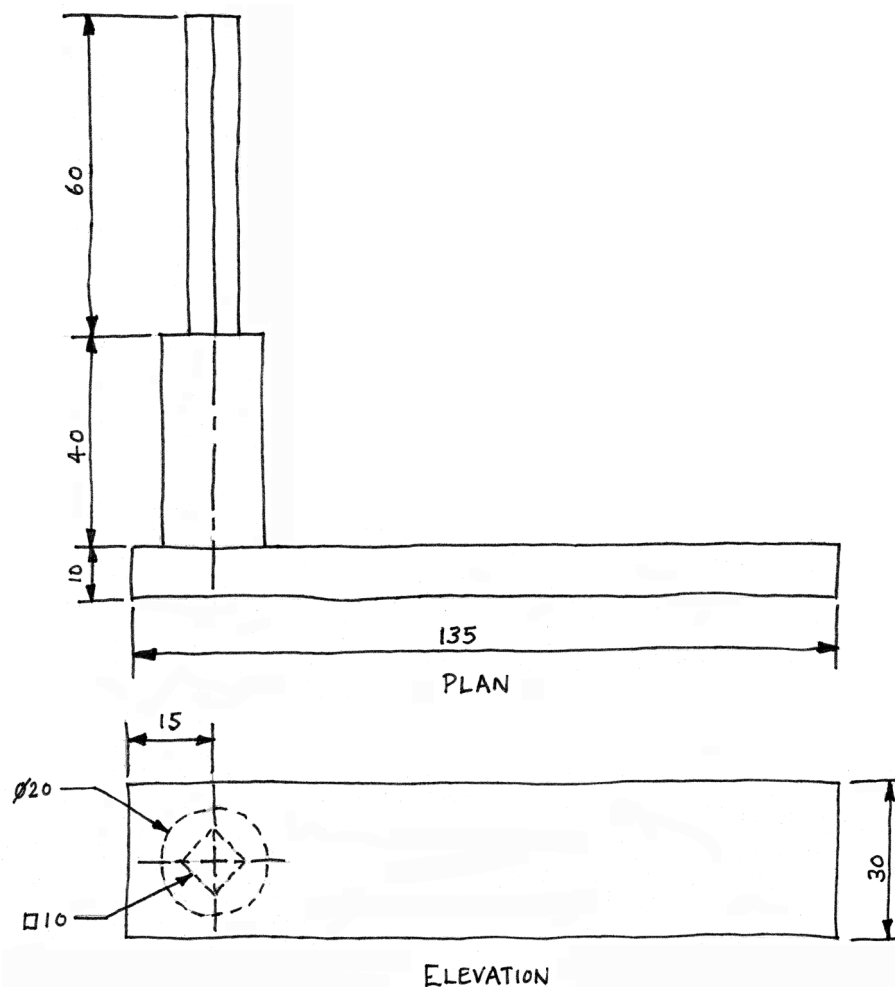

* X 7 3 5 7 5 0 1 1 4 *

7. (continued)

A $\varnothing 20$ circle is sketched before the extrude command is used to create step 1.

- (a) State the length of the extrusion used in step 1.

Step 1

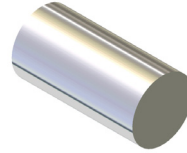

1

- (b) Describe, with reference to correct dimensions and 3D CAD modelling terms, how you would complete step 2 and step 3.

Step 2

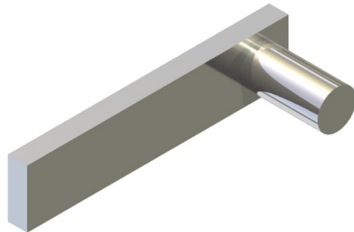

Step 3

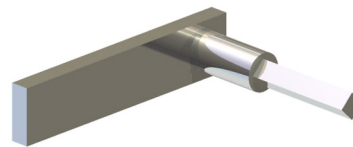

You may use sketches to support your answer.

4

7. (continued)

The door plate is needed to secure the handle to the door. The production orthographic drawing (not to scale) for the door plate is shown below.

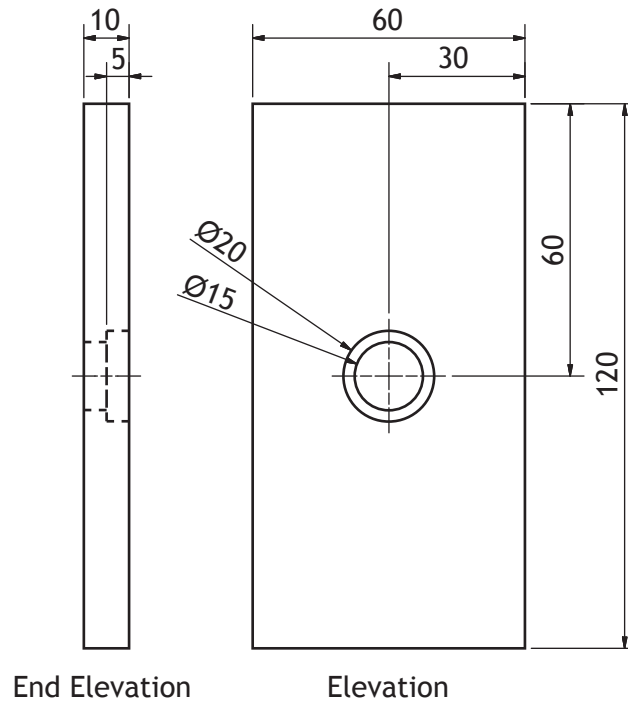

(c) Describe, with reference to correct dimensions and 3D CAD modelling terms, how you would create the door plate.

You may use sketches to support your answer.

3



7. (continued)

In order to manufacture the door plate, the back of the plate is hollowed out as shown below.



- (d) State the name of the 3D modelling technique used to hollow the door plate. 1

- (e) State **three** advantages of computer aided drawing over manual drawing methods. 3

Advantage 1 _____

Advantage 2 _____

Advantage 3 _____

When producing the door plate the CAD command 'zoom' is used.

- (f) State one way in which the 'zoom' command would be useful. 1

Total marks 13

[Turn over for Question 8 on *Page eighteen*]



8. Two graphic items A and B are shown below.

(a) Indicate, using a tick (✓), if Graphic Item A is:

Preliminary

Promotional

Production



Graphic Item A

1

(b) Indicate, using a tick (✓), if Graphic Item B is:

Preliminary

Promotional

Production

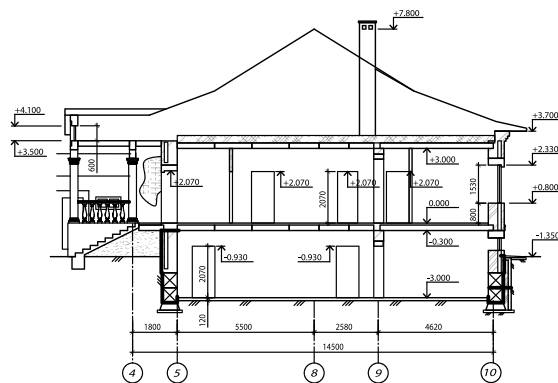
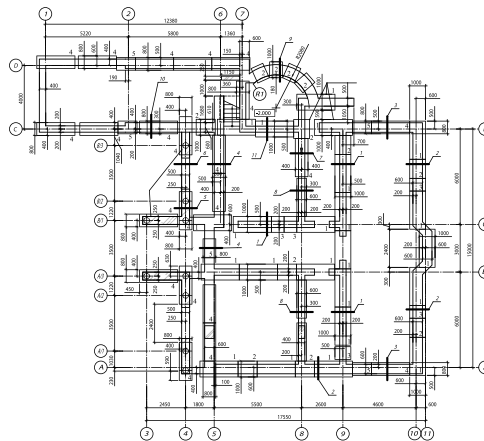

Graphic Item B

1

Total marks 2

[END OF QUESTION PAPER]



* X 7 3 5 7 5 0 1 1 8 *



ADDITIONAL SPACE FOR ANSWERS

MARKS

DO NOT
WRITE IN
THIS
MARGIN

--



* X 7 3 5 7 5 0 1 1 9 *



ADDITIONAL SPACE FOR ANSWERS

MARKS

DO NOT
WRITE IN
THIS
MARGIN

--



* X 7 3 5 7 5 0 1 2 0 *



ACKNOWLEDGEMENTS

Question 2—103887632 AlexRoz/Shutterstock.com

Question 8(a)—106511447 Lena Pan/Shutterstock.com

Question 8(b)—113272513 Shutterstock.com

