

FOR OFFICIAL USE



--	--	--	--	--	--

National
Qualifications
2017

Mark

--

X735/76/01

Graphic Communication

WEDNESDAY, 10 MAY

1:00 PM – 3:00 PM



Fill in these boxes and read what is printed below.

Full name of centre

--

Town

--

Forename(s)

--

Surname

--

Number of seat

--

Date of birth

Day

--	--

Month

--	--

Year

--	--

Scottish candidate number

--	--	--	--	--	--	--	--	--	--

Total marks — 70

Attempt ALL questions.

All dimensions are in mm.

All technical sketches and drawings use third angle projection.

You may use rulers, compasses or trammels for measuring.

In all questions you may use sketches and annotations to support your answer if you wish.

Write your answers clearly in the spaces provided in this booklet. Additional space for answers is provided at the end of this booklet. If you use this space you must clearly identify the question number you are attempting.

Use **blue** or **black** ink.

Before leaving the examination room you must give this booklet to the Invigilator; if you do not, you may lose all the marks for this paper.



1. A CAD technician created a 3D model of the bicycle, shown below.



(a) (i) Describe, giving two reasons, how a 3D CAD model can be used to aid production.

2

(ii) Describe, giving two reasons, how the 3D CAD model can be used to support manufacture through testing.

2



1. (continued)

MARKS
DO NOT
WRITE IN
THIS
MARGIN

(b) A new brake disc design was requested for the bicycle.

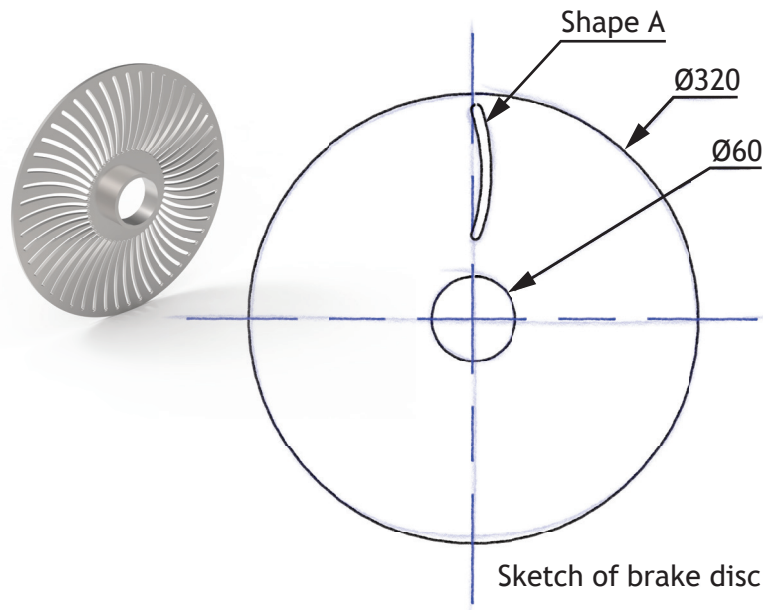

Shape A was to be repeated 60 times. State the CAD edit that would be used to create the feature.

1

[Turn over



1. (continued)

MARKS
DO NOT
WRITE IN
THIS
MARGIN

(c) The bicycle uses a spring as part of the suspension system, shown below.

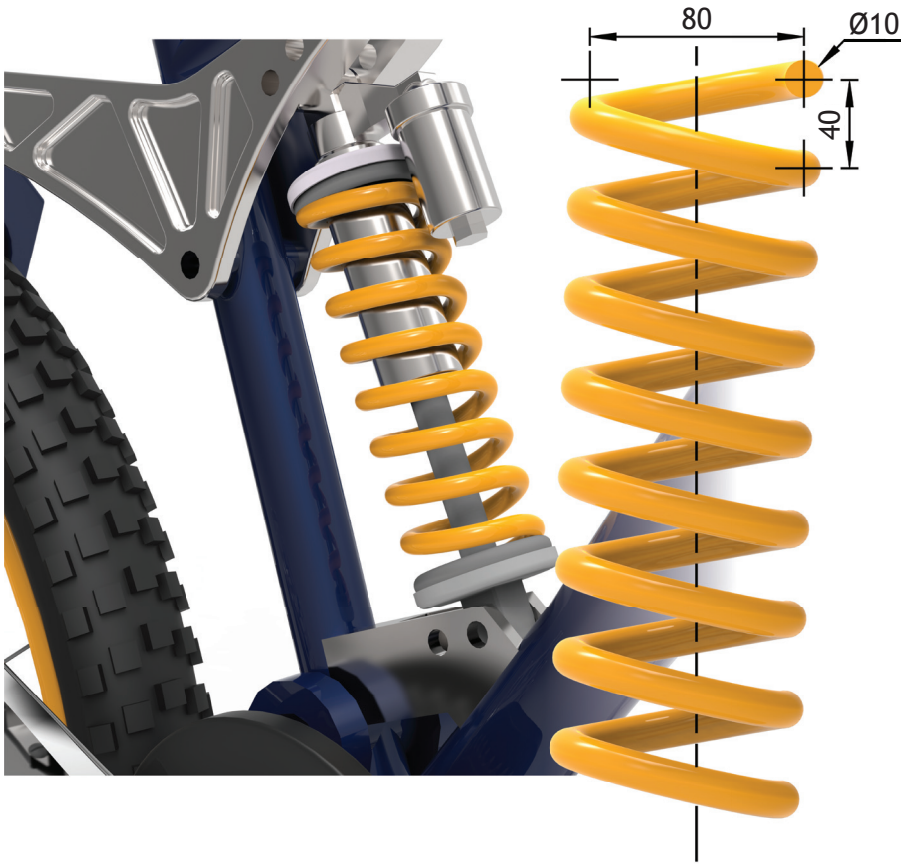

The spring was modelled as a separate component using 3D CAD.

Describe the 3D CAD technique used to model the spring.

You must make reference to the dimensions above.

You may use sketches to illustrate your answer.

3

Blank area for the student's answer.



1. (continued)

MARKS
DO NOT
WRITE IN
THIS
MARGIN

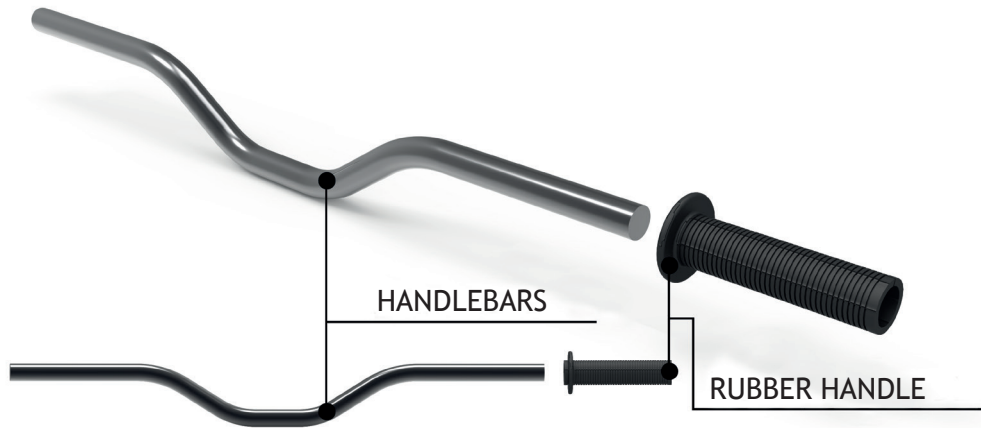

- (d) The handlebars were 3D CAD modelled as a single component. Describe the modelling technique used to generate the component. You may use sketches to illustrate your answer.

2

Rubber handles were required to cover the handlebars. The CAD technician used top down modelling to create the rubber handles.

- (e) Describe two advantages of **top down modelling** in relation to these components.

2



1. (continued)

- (f) The shape of the rubber handle was sketched prior to being modelled using 3D CAD.

The orthographic sketch of the rubber handle is shown below.

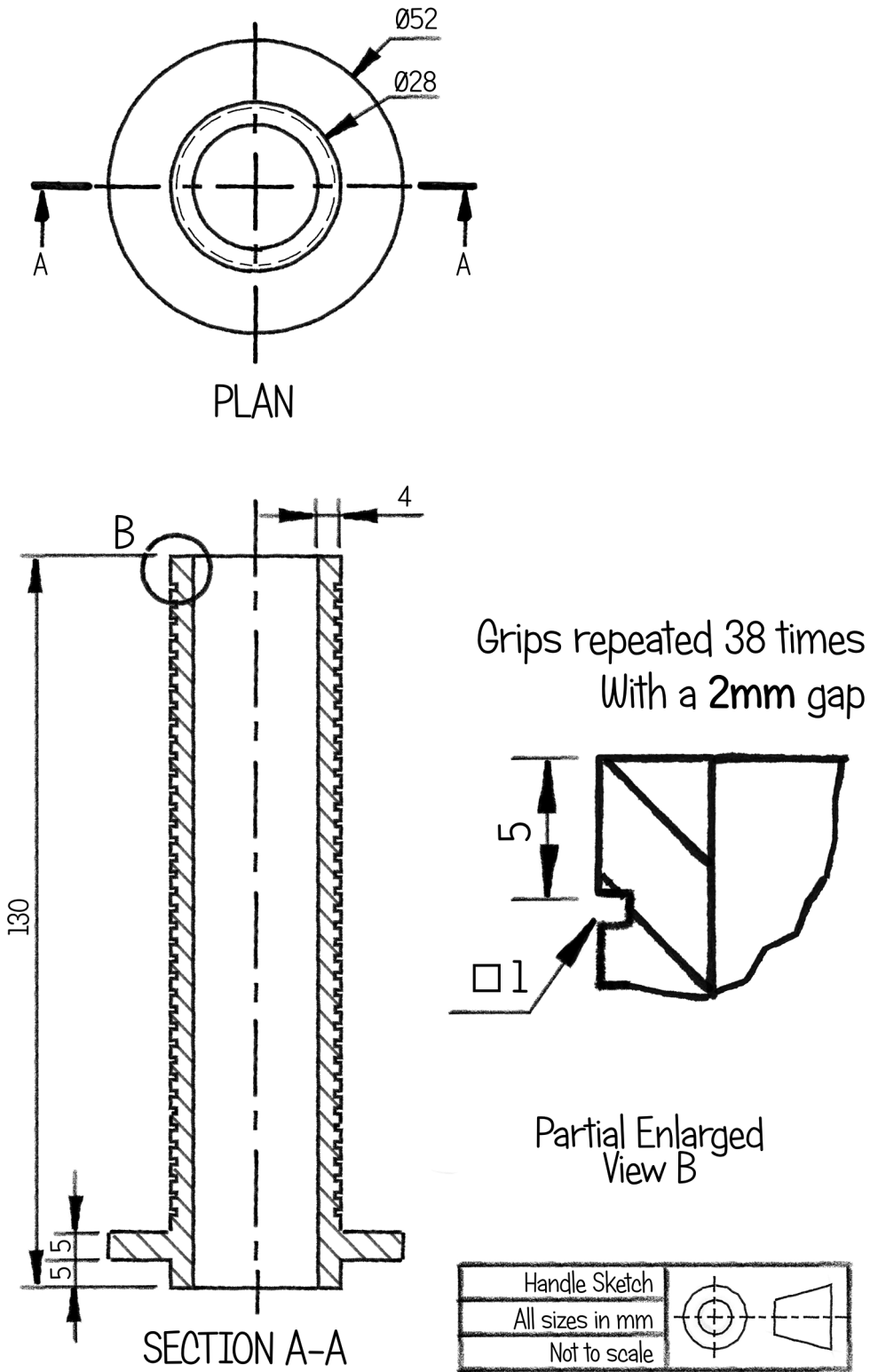

DO NOT
WRITE IN
THIS
MARGIN



* X 7 3 5 7 6 0 1 0 6 *

1. (f) (continued)

MARKS

DO NOT
WRITE IN
THIS
MARGIN

Describe the 3D CAD technique used to model the rubber handle with reference to the dimensions in the sketch of the handle (shown opposite).

6

You may use sketches to illustrate your answer.

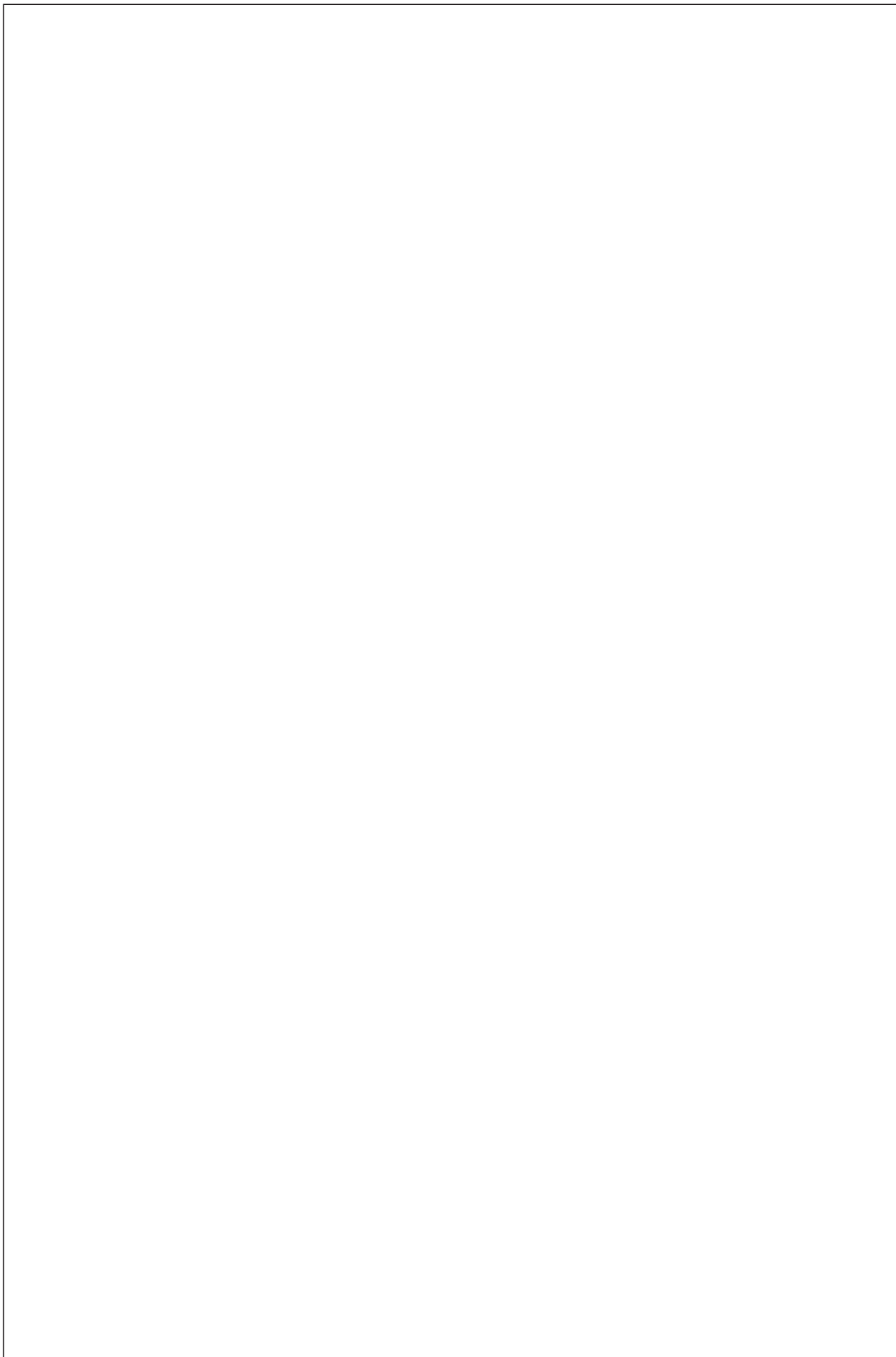

* X 7 3 5 7 6 0 1 0 7 *

1. (continued)

MARKS
DO NOT
WRITE IN
THIS
MARGIN

(g) Two sectional views of the bicycle crank are shown below.

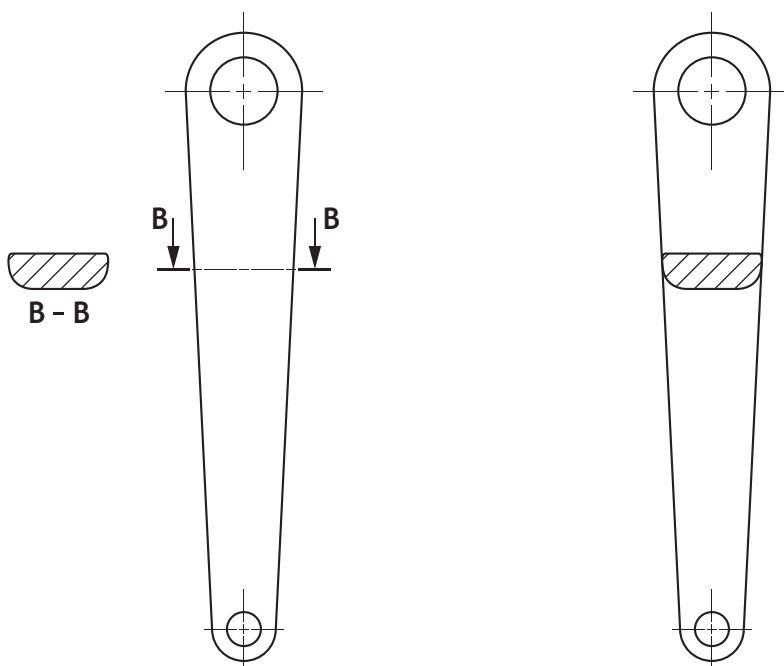

Figure 1

Figure 2

(i) State the type of sectional view shown in Figure 1.

1

(ii) State the type of sectional view shown in Figure 2.

1



* X 7 3 5 7 6 0 1 0 8 *

[Turn over for next question

DO NOT WRITE ON THIS PAGE



* X 7 3 5 7 6 0 1 0 9 *

2. Graphics 1 and 2 are both used within the building industry and serve different purposes.



Graphic 1

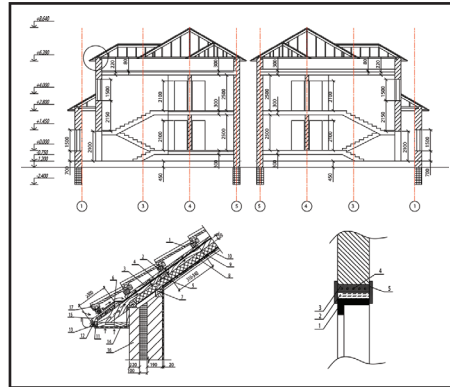

Graphic 2

- (a) State the intended user and explain the purpose of each graphic.

- (i) Graphic 1

2

User _____

Purpose _____

- (ii) Graphic 2

2

User _____

Purpose _____



2. (continued)

MARKS
DO NOT
WRITE IN
THIS
MARGIN

(b) A construction company uses CAD software that makes use of **cloud computing**. The company engineers visit construction sites on a regular basis and require access to the most current CAD data.

(i) Describe two advantages that **cloud computing** can offer the construction company. 2

(ii) Describe two disadvantages of **cloud storage**. 2

[Turn over



* X 7 3 5 7 6 0 1 1 1 *

3. A layout from a health magazine is shown below.

(a) The graphic designer has used **emphasis** in the layout shown above. Describe how each of these items has been emphasised.

(i) The pull quote. 1

(ii) The body text. 1

(iii) The photograph of the model. 1



3. (continued)

MARKS

DO NOT
WRITE IN
THIS
MARGIN

- (b) Explain, giving two reasons, why the graphic designer has limited the use of colour in the layout.

2

- (c) Describe the effect of using both serif and sans serif fonts in this layout.

1

- (d) The title is in a serif typeface which the graphic designer felt was suitable for use in the layout.

Explain why this is a suitable typeface for this layout.

1

- (e) Describe how the graphic designer has created **rhythm** in the layout.

1

- (f) Describe how the graphic designer has created **texture** in the layout.

1

- (g) Describe how the graphic designer has used **value** in the layout.

1

[Turn over



* X 7 3 5 7 6 0 1 1 3 *

4. A graphic designer for a sports magazine created Layout 1 as a draft idea for a basketball article.

The magazine editor suggested DTP features to create better visual impact.

The graphic designer then produced a second draft, Layout 2.

DO NOT WRITE IN THIS MARGIN



Layout 1



Layout 2



* X 7 3 5 7 6 0 1 1 4 *

4. (continued)

MARKS

DO NOT
WRITE IN
THIS
MARGIN

(a) Identify four additional DTP features that have been added to Layout 2 and explain, giving two reasons for each, how they improve the layout.

(i) (A) Feature _____ 1

(B) Reasons _____ 2

(ii) (A) Feature _____ 1

(B) Reasons _____ 2

(iii) (A) Feature _____ 1

(B) Reasons _____ 2

(iv) (A) Feature _____ 1

(B) Reasons _____ 2

[Turn over



* X 7 3 5 7 6 0 1 1 5 *

4. (continued)

MARKS

DO NOT
WRITE IN
THIS
MARGIN

(b) High-resolution images used in the magazine were downloaded from a photo stock website for a small cost.

(i) Explain what is meant by the term high-resolution.

1

(ii) State the name of a suitable file type for an image.

1



(c) Prior to paying for the high-resolution images, low-resolution samples were available to download for free. These images contained watermarks, as shown above.

Explain, giving two reasons, why watermarks are added to the free images.

2



* X 7 3 5 7 6 0 1 1 6 *

[Turn over for next question

DO NOT WRITE ON THIS PAGE



* X 7 3 5 7 6 0 1 1 7 *

5. A packaging proposal is shown below.

DO NOT
WRITE IN
THIS
MARGIN

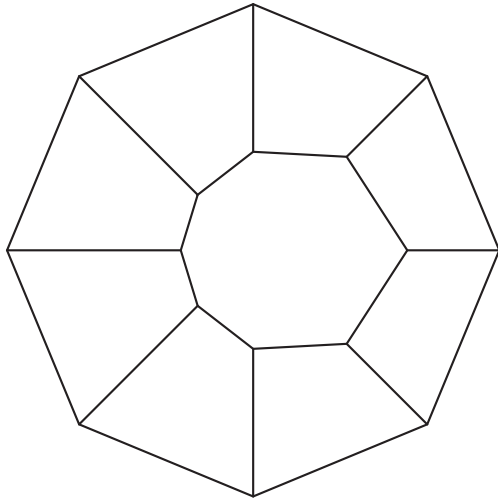

PLAN

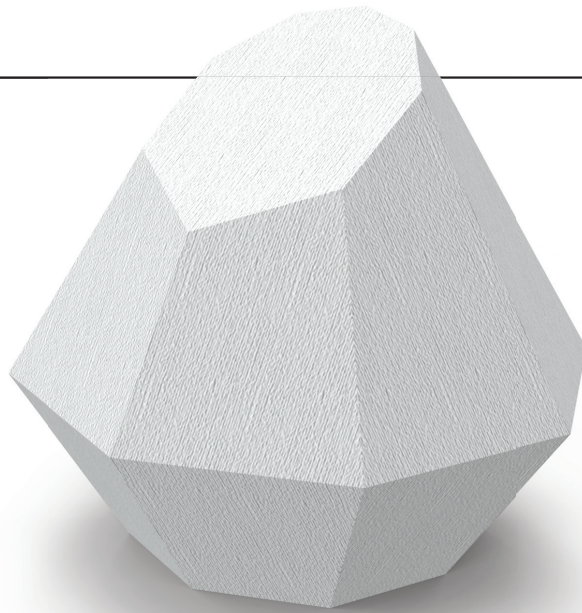

RENDERED PICTORIAL
NOT TO SCALE

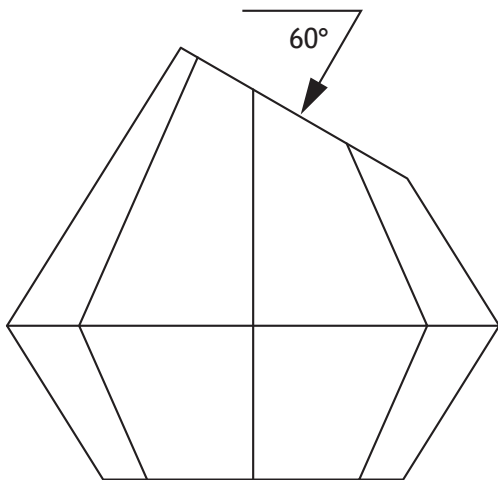

ELEVATION

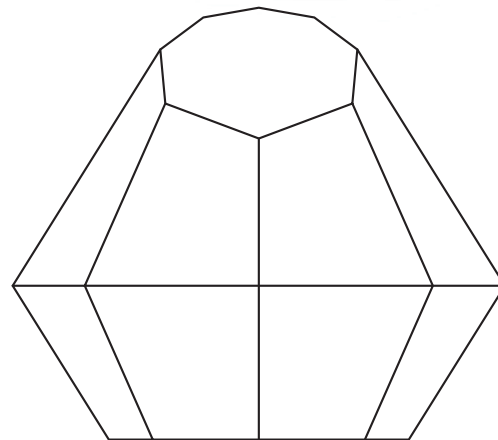

END ELEVATION

PACKAGING
SCALE 1:1

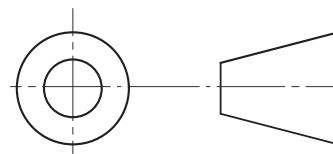

* X 7 3 5 7 6 0 1 1 8 *

5. (continued)

- (a) Indicate the correct auxiliary view by ticking (✓) a box below.
Use a ruler, trammel or compasses to measure.

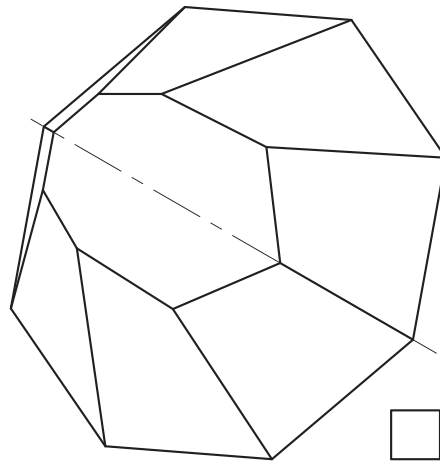
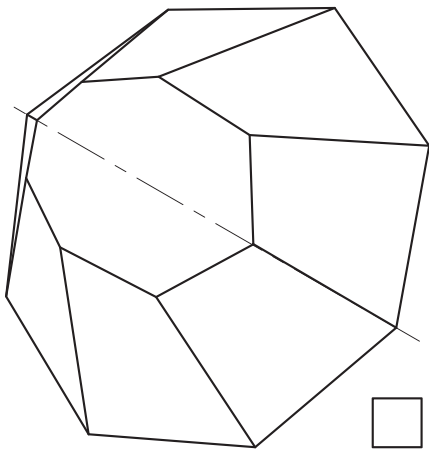
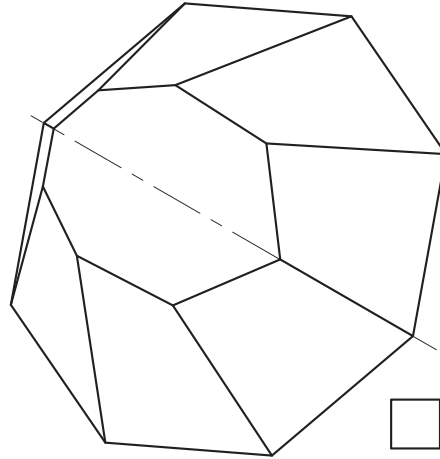
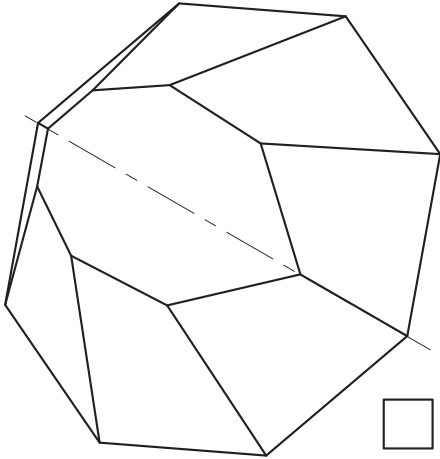

[Turn over



5. (continued)

MARKS
DO NOT WRITE IN THIS MARGIN

(b) The orthographic drawing of the packaging is shown below. The packaging will have different information on various faces.

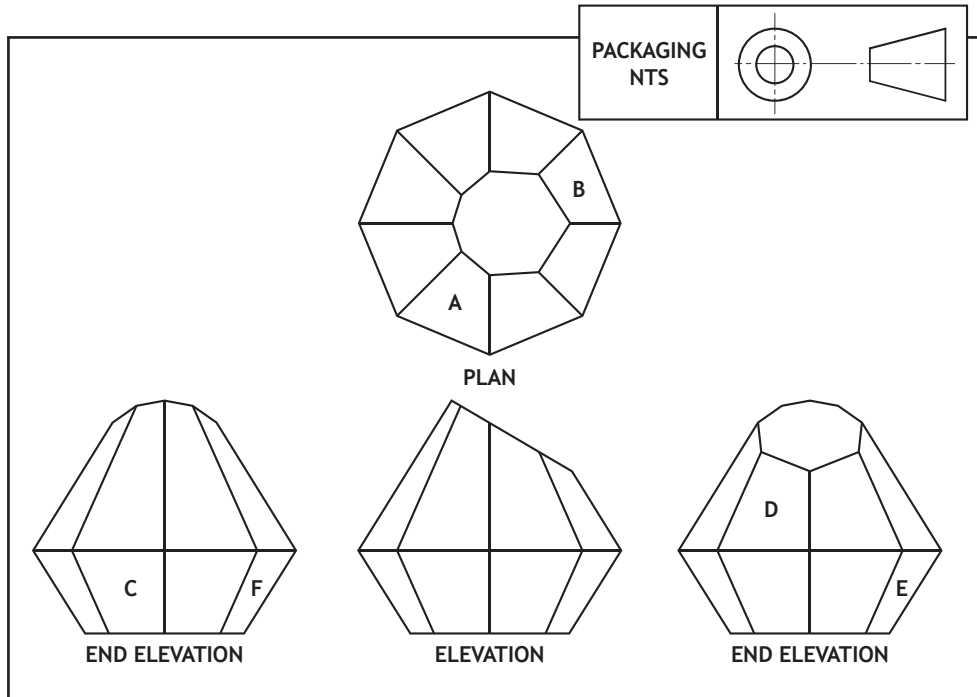

Indicate the position of faces A–F on the surface development below.
The surface development is shown from the **outside**.

6

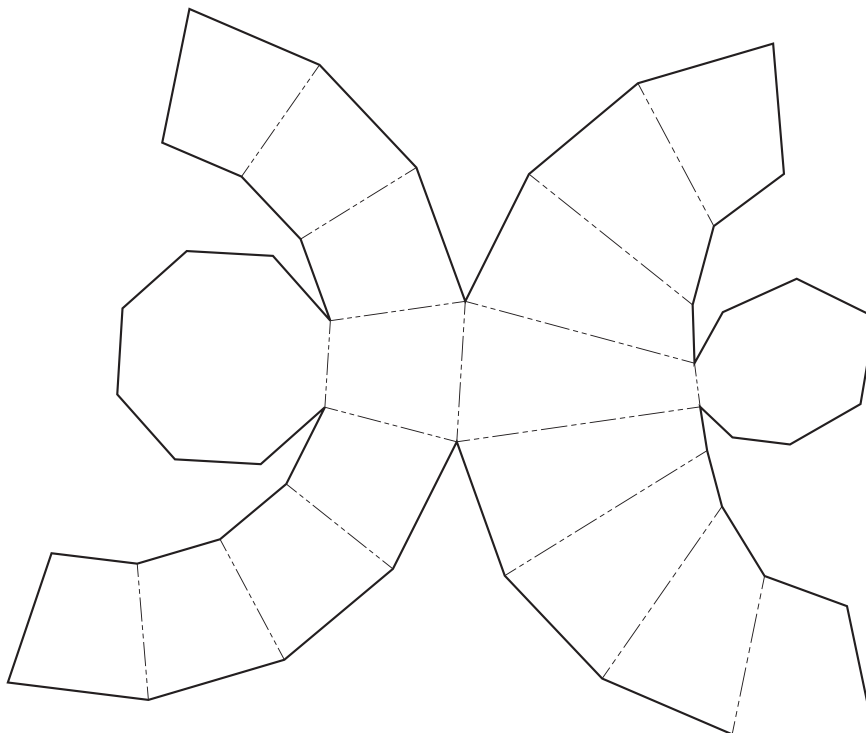

6. A CAD technician created a 3D model and technical drawing of an oil pump. Use the exploded view and parts list on the **Supplementary Sheet for use with Question 6**, provided, to answer this question.

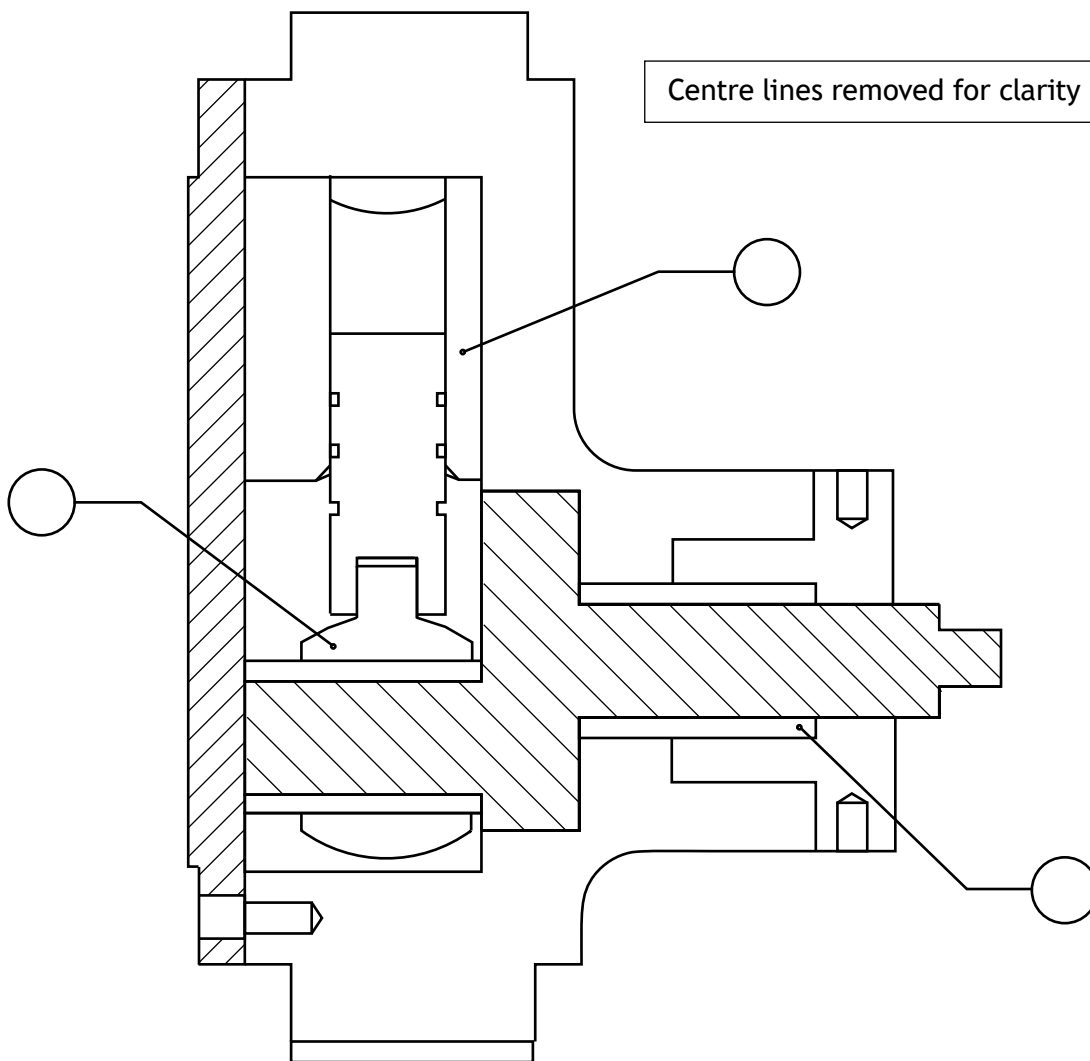

SECTION A-A

- (a) Complete Section A–A above by applying hatching lines to appropriate areas in accordance to British Standard conventions. 6
- (b) Add the part number of the three components indicated on Section A–A above. 3

[END OF QUESTION PAPER]



* X 7 3 5 7 6 0 1 2 1 *

MARKS

DO NOT
WRITE IN
THIS
MARGIN

ADDITIONAL SPACE FOR ANSWERS



* X 7 3 5 7 6 0 1 2 2 *

MARKS

DO NOT
WRITE IN
THIS
MARGIN

ADDITIONAL SPACE FOR ANSWERS



* X 7 3 5 7 6 0 1 2 3 *

[BLANK PAGE]

DO NOT WRITE ON THIS PAGE

Acknowledgement of Copyright

- Question 2 Nikonaft/shutterstock.com
 marina_ua/shutterstock.com
- Question 3 Casey K. Bishop/shutterstock.com
 ElenaGaak/shutterstock.com
 13Imagery/ shutterstock.com
 One AND only/shutterstock.com
 ORLIO/shutterstock.com
 Irina Bg/shutterstock.com
- Question 4 Eugene Onischenko/shutterstock.com
 Eugene Onischenko/shutterstock.com





National
Qualifications
2017

X735/76/11

**Graphic Communication
Supplementary Sheet**

WEDNESDAY, 10 MAY

1:00 PM – 3:00 PM

Supplementary Sheet for use with Question 6.



* X 7 3 5 7 6 1 1 *

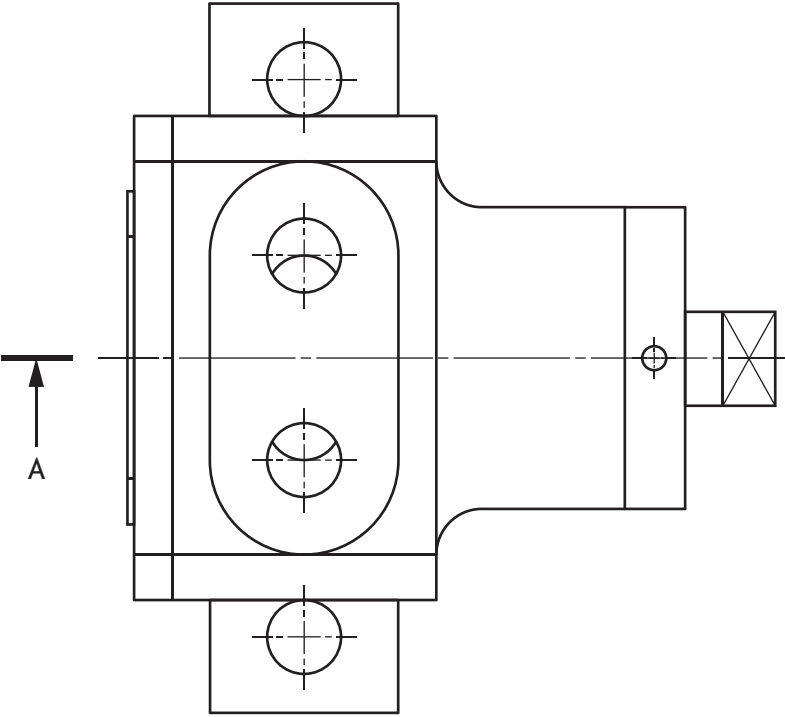

PLAN

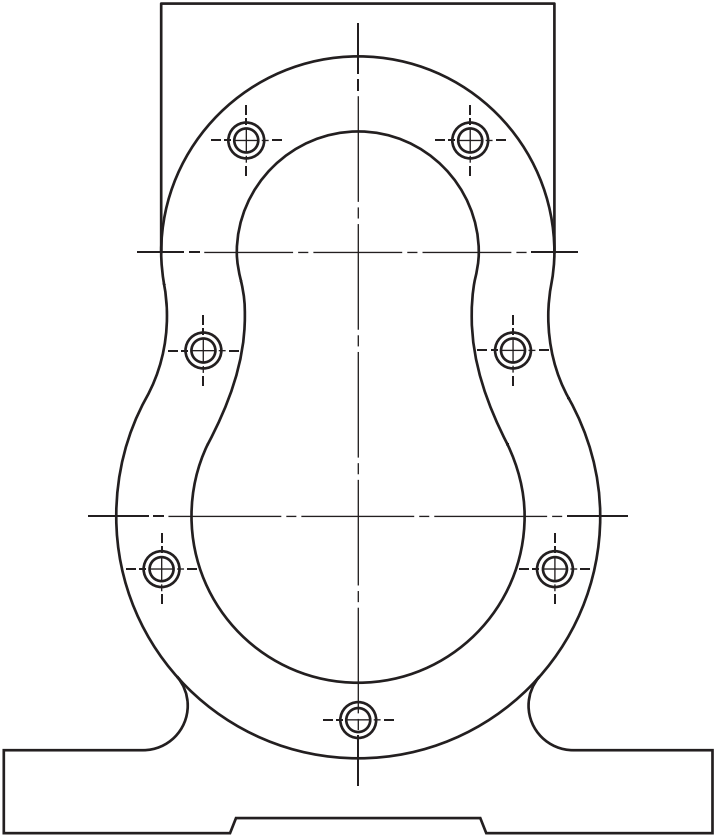

END ELEVATION

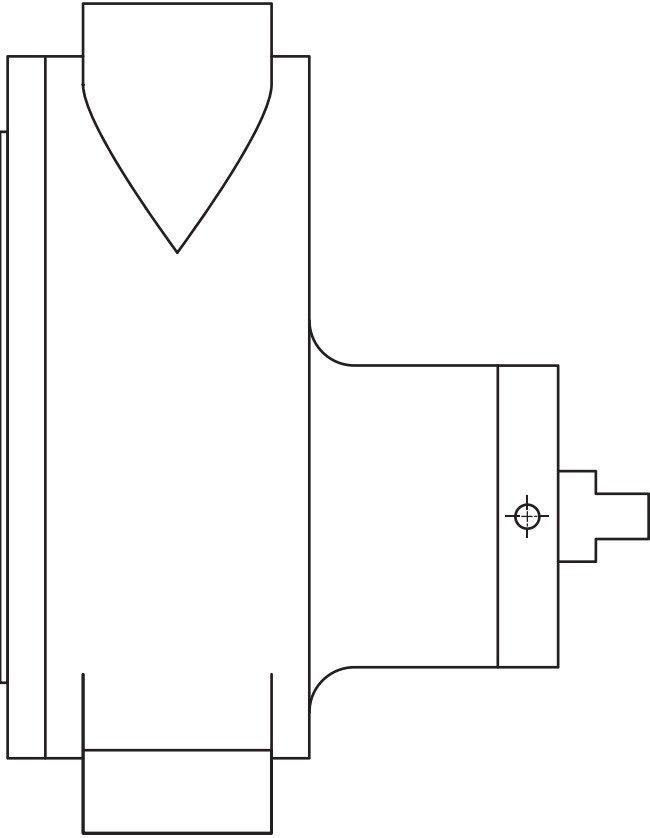

ELEVATION

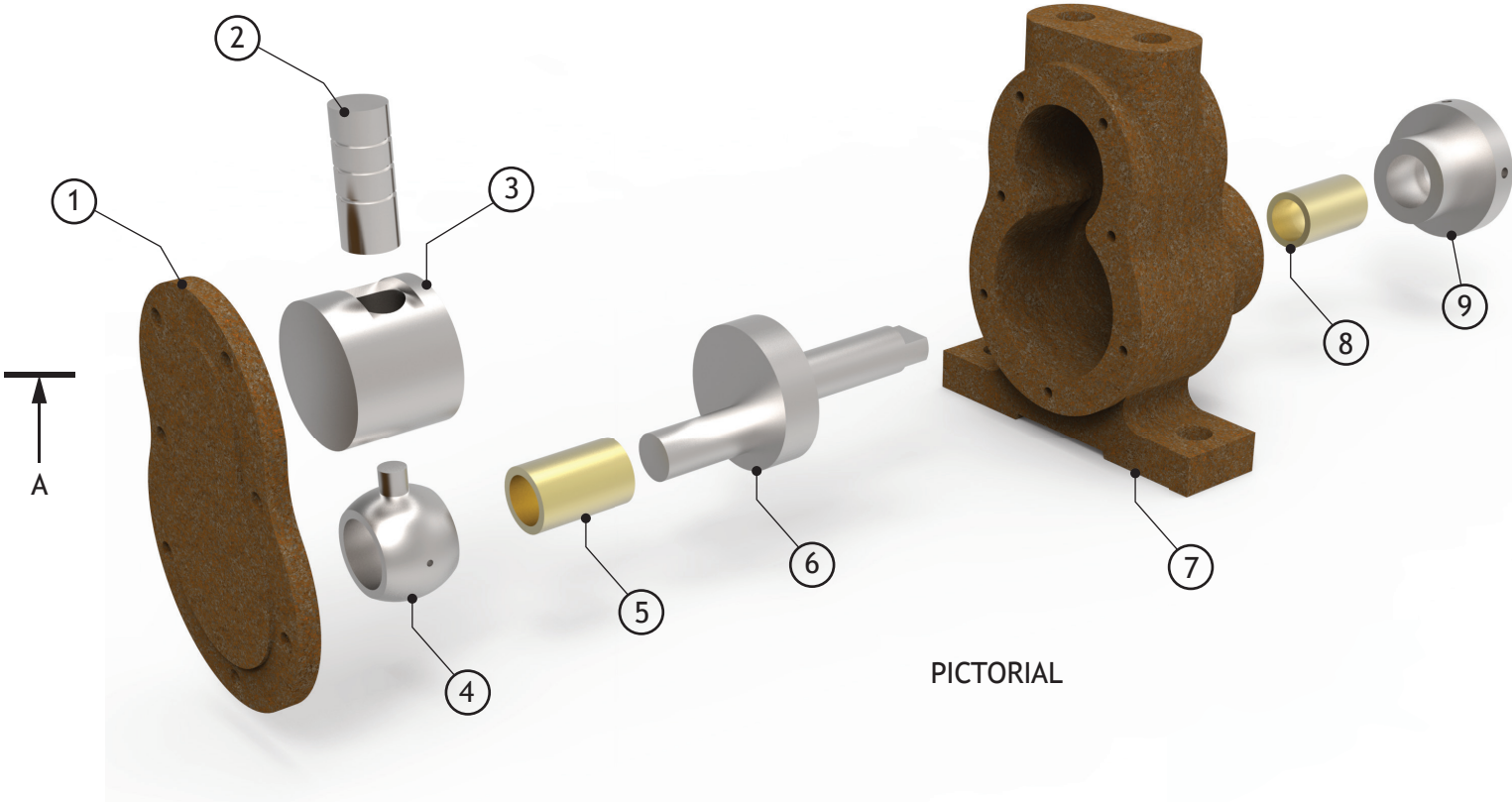

PICTORIAL

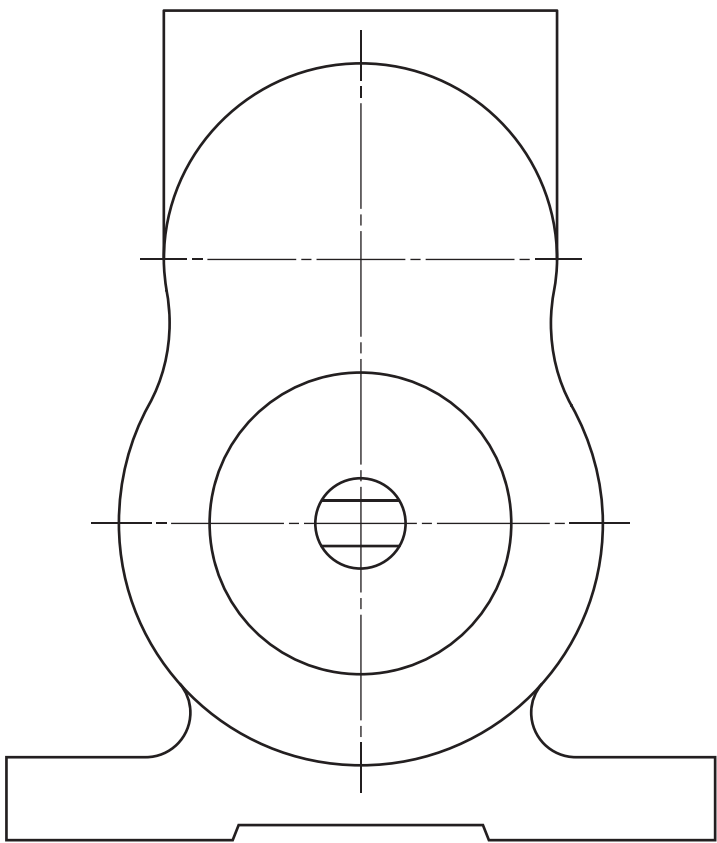

END ELEVATION

DRAWING TITLE		ASSEMBLY	
QUESTION TITLE		OIL PUMP	
COURSE		HIGHER GRAPHIC COMMUNICATION	
DATE			
SCALE	NTS		
SHEET	1/1		
		ALL SIZES IN MM DO NOT SCALE	

[BLANK PAGE]

DO NOT WRITE ON THIS PAGE