

FOR OFFICIAL USE



National  
Qualifications  
2019

Mark

**X735/77/01**

**Graphic Communication**

TUESDAY, 21 MAY

1:00 PM – 3:00 PM



\* X 7 3 5 7 7 0 1 \*

Fill in these boxes and read what is printed below.

Full name of centre

Town

Forename(s)

Surname

Number of seat

Date of birth

Day

Month

Year

Scottish candidate number

**Total marks — 80**

Attempt ALL questions.

All dimensions are in mm.

All technical sketches and drawings use third angle projection.

You may use rulers, compasses or trammels for measuring.

In all questions you may use sketches and annotations to support your answer if you wish.

Write your answers clearly in the spaces provided in this booklet. Additional space for answers is provided at the end of this booklet. If you use this space you must clearly identify the question number you are attempting.

Use **blue** or **black** ink.

Before leaving the examination room you must give this booklet to the Invigilator; if you do not, you may lose all the marks for this paper.



\* X 7 3 5 7 7 0 1 0 1 \*

1. A CAD model of an egg timer is shown below.



The CAD model was produced using bottom up modelling.

- a) Explain the terms top down and bottom up modelling.

2

Top down \_\_\_\_\_

\_\_\_\_\_

Bottom up \_\_\_\_\_

\_\_\_\_\_

Technical graphics of the glass container and the supporting leg will be used by the manufacturer of the egg timer. These graphics are shown on the **supplementary sheet for use with question 1**. The supporting leg is annotated with TOLERANCE A. The glass container is annotated with DATUM FACE B.

- (b) (i) Explain why TOLERANCE A, applied to the leg of the egg timer, is different from the general tolerance applied to the dimensions.

1

\_\_\_\_\_

\_\_\_\_\_

- (ii) Describe two reasons for including DATUM FACE B in the technical graphics used by the manufacturer.

2

\_\_\_\_\_

\_\_\_\_\_

\_\_\_\_\_

\_\_\_\_\_



1. (continued)

MARKS  
DO NOT  
WRITE IN  
THIS  
MARGIN

- (c) Describe the 3D CAD modelling techniques used to create the 'glass container'. You must include the terms 'tangent constraint', 'mirror' and 'shell' in your answer. Refer to the supplementary sheet for use with question 1.

Make reference to relevant dimensions from the drawings in your answer.  
You may use sketches to support your answer.

6



## 1. (continued)

- (d) Describe the 3D CAD modelling techniques used to create the 'supporting leg' of the egg timer. Refer to the supplementary sheet for use with question 1.

Make reference to the dimensions from the drawings in your answer.

You may use sketches to support your answer.

5



\* X 7 3 5 7 7 0 1 0 4 \*

2. An international airline has asked a graphic designer to plan and produce an animation to help inform passengers of the safety procedures on board its planes.



Motion tweening was used to create the animation.

- (a) Describe three key setup requirements, in addition to selecting the character and positioning the first frame, when producing a motion tweening animation.

3

---



---



---



---



---



---



---



---



---



---



\* X 7 3 5 7 7 0 1 0 5 \*

2. (continued)

(b) State an appropriate file format which can be used to save the animation.

1

---

(c) (i) Describe **two** advantages to the **airline passengers** of using an animation rather than printed safety information.

2

---



---



---



---



---



---

(ii) Describe **two** disadvantages to the **airline company** of creating an animation rather than printed safety information.

2

---



---



---



---



---



---



\* X 7 3 5 7 7 0 1 0 6 \*

3. An annual extreme sports event attracts visitors from around the world. A design for a promotional flag advertising the event is shown on the supplementary sheet for use with question 3.

(a) Describe how the designer has used 'silhouette', 'negative space' and 'balance' to give the flag maximum visual impact.

3

Silhouette \_\_\_\_\_

---



---

Negative space \_\_\_\_\_

---



---

Balance \_\_\_\_\_

---



---

(b) Explain, giving two reasons, why the designer chose to create the flag graphic using vector graphics software.

2

---



---



---



---



---



---

[Turn over



\* X 7 3 5 7 7 0 1 0 7 \*

3. (continued)

(c) The source graphic of the biker was a photograph.

Image 1



Image 2



(i) State a suitable raster file type for saving the photograph shown in Image 1.

1

---

(ii) State a suitable vector file type for saving the finished biker image used on the flag shown in Image 2.

1

---

Three methods were considered for producing the city scape image used in the flag.

- Method 1, creating a 3D model of the city scape and exporting the resulting image.
- Method 2, creating a sketch and then using a scanner to generate the image.
- Method 3, using a 'Shutterstock' image.

(d) (i) Describe two advantages to the graphic designer of using method 1.

2

---



---



---



---



---



---



## 3. (d) (continued)

(ii) Describe two advantages of using method 2.

2

---

---

---

---

---

---

---

(iii) Describe two advantages of using method 3.

2

---

---

---

---

---

---

---

[Turn over



\* X 7 3 5 7 7 0 1 0 9 \*

3. (continued)

MARKS

DO NOT  
WRITE IN  
THIS  
MARGIN

The designer received a digital proof from the printer for final checking.

(e) Explain, giving two reasons, why the following are critical to the quality of the printed flag.

(i) Registration marks

2

---

---

---

---

---

---

---

(ii) Colour calibration

2

---

---

---

---

---

---

---

(f) Explain, giving three reasons, why the company would protect the rights to the graphics produced for the event.

3

---

---

---

---

---

---

---

---

---

---

---



\* X 7 3 5 7 7 0 1 1 0 \*

3. (continued)

MARKS  
DO NOT  
WRITE IN  
THIS  
MARGIN

T-shirts are available to buy at the event as part of a range of promotional merchandise. Two of the T-shirt designs are shown below.



- (g) (i) State the name of an appropriate printing process for the T-shirt design. 1

\_\_\_\_\_

- (ii) Explain, giving three reasons, why this printing process is suitable. 3

\_\_\_\_\_  
\_\_\_\_\_  
\_\_\_\_\_  
\_\_\_\_\_  
\_\_\_\_\_  
\_\_\_\_\_  
\_\_\_\_\_  
\_\_\_\_\_  
\_\_\_\_\_

[Turn over



4. A small housing development is being planned within a conservation area. Three built environment surveys have been completed and the results are shown in the graphics 1 to 3 below.

Graphic 1

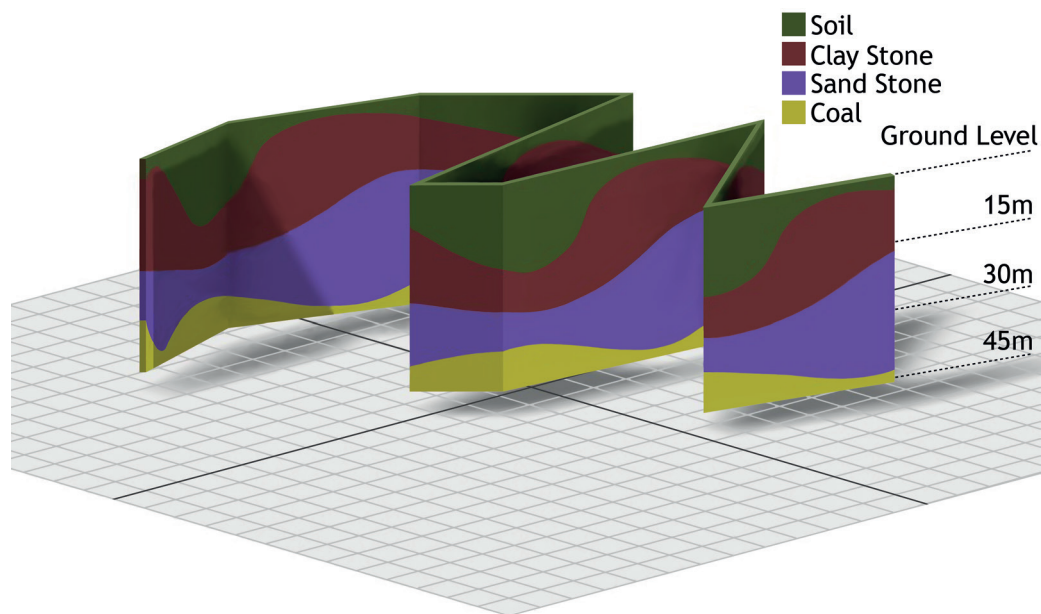

- (a) (i) State the name of the survey that produced the result illustrated in Graphic 1.

1

Survey type \_\_\_\_\_

- (ii) Explain the purpose of this survey with respect to the housing development.

2

Purpose \_\_\_\_\_

\_\_\_\_\_

\_\_\_\_\_

\_\_\_\_\_

\_\_\_\_\_

4. (a) (continued)

Graphic 2

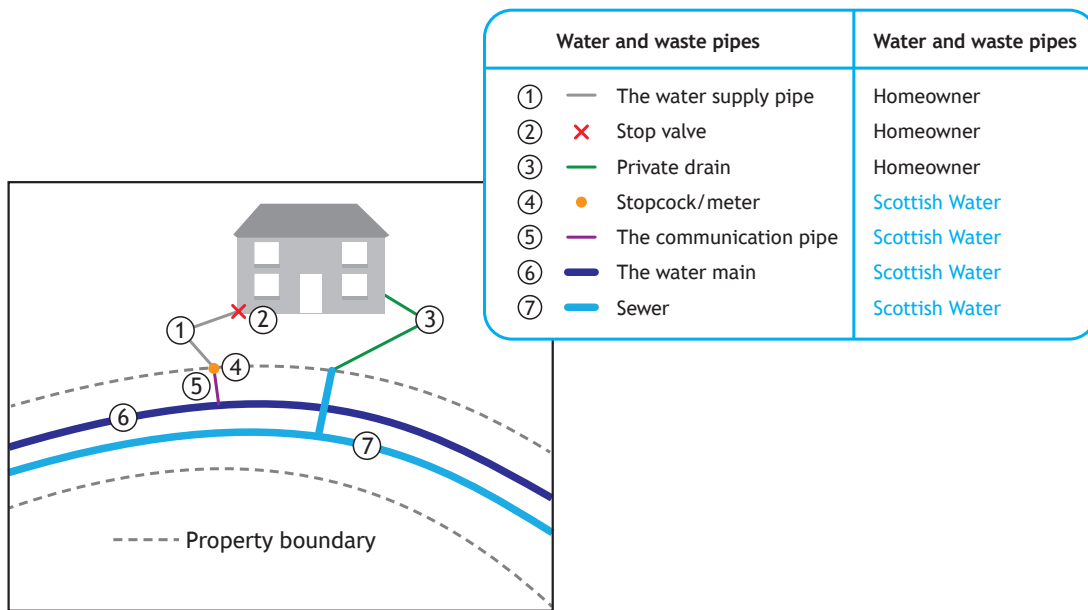

(iii) State the name of the survey that produced the results illustrated in Graphic 2.

1

Survey type \_\_\_\_\_

(iv) Explain the purpose of this survey with respect to the housing development.

2

Purpose \_\_\_\_\_

\_\_\_\_\_

\_\_\_\_\_

\_\_\_\_\_

\_\_\_\_\_

[Turn over



4. (a) (continued)

Graphic 3

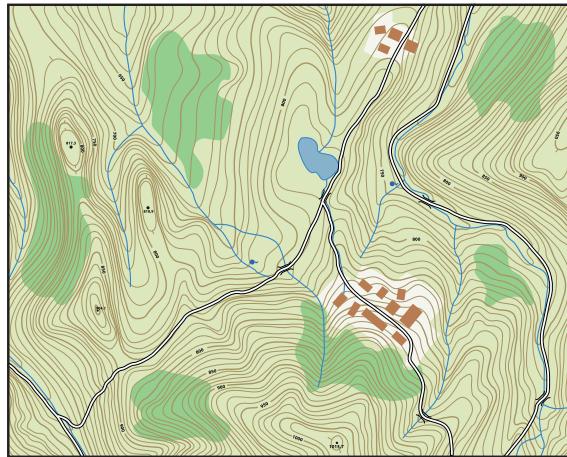

1:25000

- (v) State the name of the survey that produced the results shown in Graphic 3.

1

Survey type \_\_\_\_\_

- (vi) Explain the purpose of this survey with respect to the housing development.

2

Purpose \_\_\_\_\_

\_\_\_\_\_

\_\_\_\_\_

\_\_\_\_\_

\_\_\_\_\_



\* X 7 3 5 7 7 0 1 1 4 \*

[Turn over for next question

DO NOT WRITE ON THIS PAGE



\* X 7 3 5 7 7 0 1 1 5 \*

4. (continued)

(b) A preliminary graphic of one of the houses in the new development is shown below.

Graphic 1

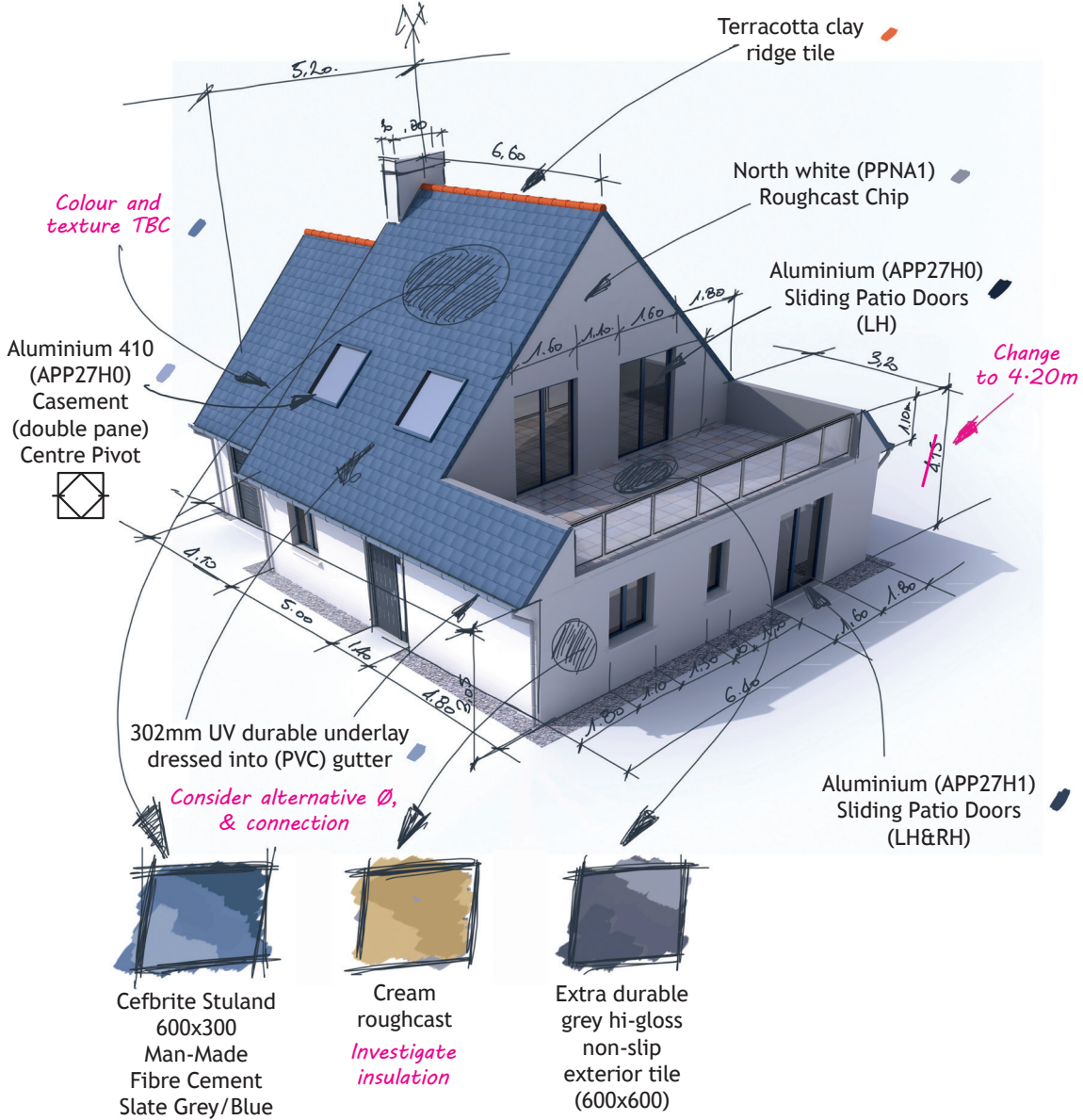



4. (b) (continued)

Explain two ways the information contained in Graphic 1 could be used by the following audiences.

(i) Quantity surveyor

2

---



---



---



---

(ii) Architectural technician

2

---



---



---



---

(iii) Conservation body

2

---



---



---



---

[Turn over



\* X 7 3 5 7 7 0 1 1 7 \*

5. A website is being created for a wind turbine company.

MARKS  
DO NOT  
WRITE IN  
THIS  
MARGIN

The initial web page layout, also known as a 'wireframe' is shown in **Graphic 1** below.

**Graphic 1: Website wireframe**

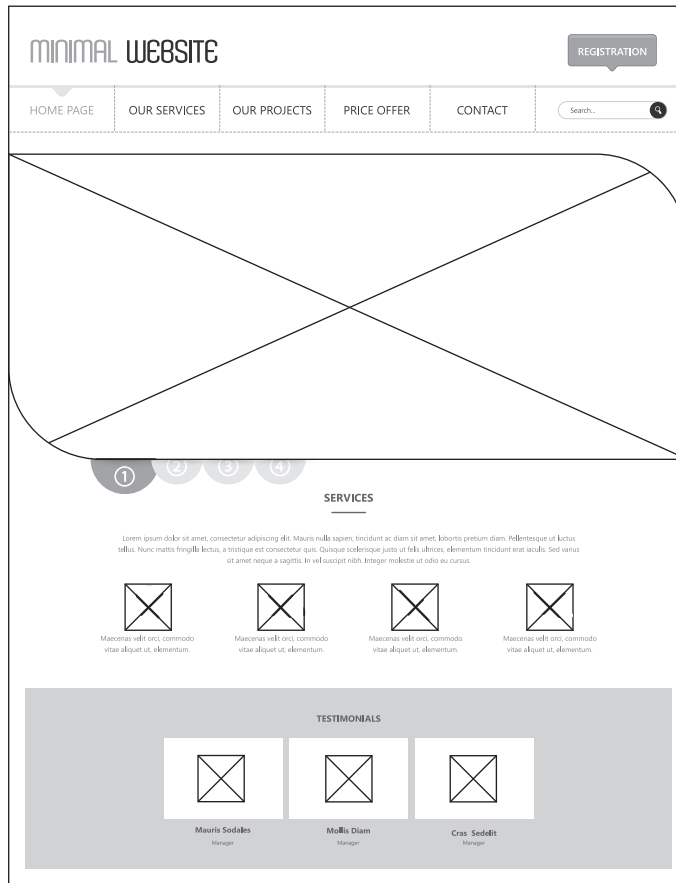

(a) Explain three purposes of using a wireframe in web design.

3

---

---

---

---

---

---

---

---

---

---



5. (continued)

MARKS  
DO NOT WRITE IN THIS MARGIN

The website will include various educational, technical and commercial information.

An educational infographic aimed at young people will be available from the website in a PDF file format, shown in **Graphic 2**.

Graphic 2: printable PDF

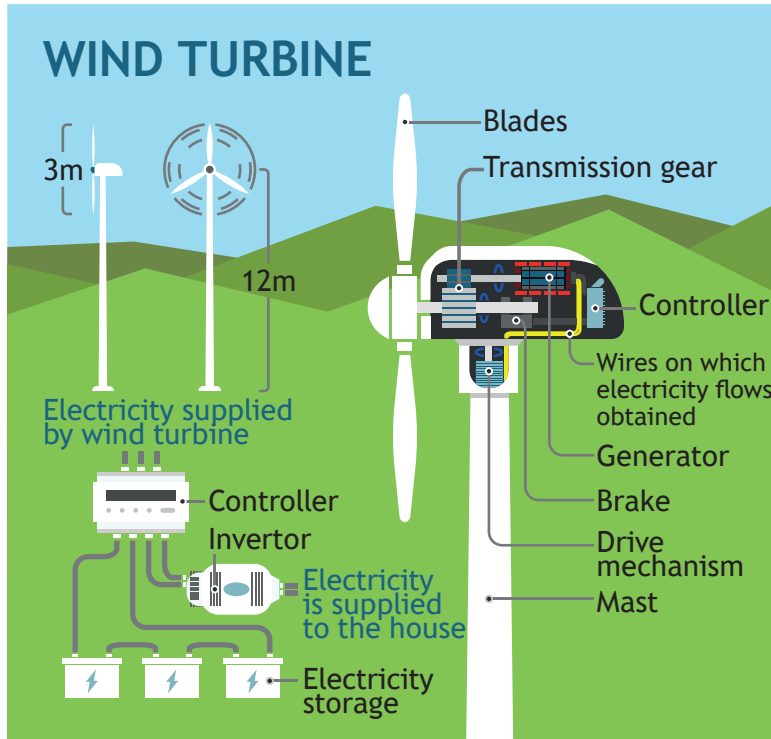

(b) Explain, with reference to design elements or principles, why the graphic is suitable for the target audience. 2

---

---

---

---

---

---

---

[Turn over



5. (continued)

MARKS

DO NOT  
WRITE IN  
THIS  
MARGIN

The company are keen to make the website as accessible and interactive as possible.

- (c) (i) Describe how the use of the following graphic file formats could make the website accessible.

2

3GP \_\_\_\_\_

\_\_\_\_\_

WMV \_\_\_\_\_

\_\_\_\_\_

- (ii) Describe how the following graphic media file formats could be used to make the website interactive.

2

VRML \_\_\_\_\_

\_\_\_\_\_

MPEG \_\_\_\_\_

\_\_\_\_\_



\* X 7 3 5 7 7 0 1 2 0 \*

5. (continued)

MARKS  
DO NOT  
WRITE IN  
THIS  
MARGIN

A new design of wind turbine is being introduced by the company. A graphic of the turbine, shown below, will feature in the website's background image.

Graphic 3: background image



(d) Explain how the image emphasises the new turbine, making reference to the following design elements and principles. Repeated responses will not attract any marks.

(i) White space 1

---

---

---

(ii) Rule of thirds 1

---

---

---

(iii) Depth of field 1

---

---

---



5. (continued)

The website will include a section on the function of the new turbine and includes **Graphic 4** shown below.

**Graphic 4: digital test**

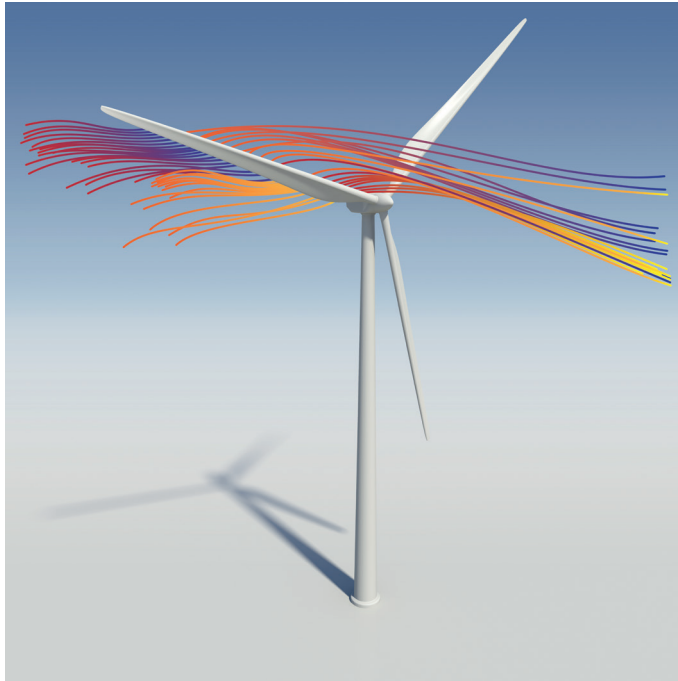

(e) (i) State the name of the digital testing method shown in **Graphic 4**. 1

\_\_\_\_\_

(ii) Describe how an engineer could make use of this test when designing the turbine. 2

\_\_\_\_\_  
\_\_\_\_\_  
\_\_\_\_\_  
\_\_\_\_\_  
\_\_\_\_\_  
\_\_\_\_\_

## 5. (e) (continued)

- (iii) Describe two factors, other than the design of the turbine, that must be considered by an engineer to make the test as realistic as possible.

2

---

---

---

---

[END OF QUESTION PAPER]



\* X 7 3 5 7 7 0 1 2 3 \*

MARKS DO NOT  
WRITE IN  
THIS  
MARGIN

ADDITIONAL SPACE FOR ANSWERS



\* X 7 3 5 7 7 0 1 2 4 \*



MARKS

DO NOT  
WRITE IN  
THIS  
MARGIN

ADDITIONAL SPACE FOR ANSWERS



\* X 7 3 5 7 7 0 1 2 5 \*

[BLANK PAGE]

DO NOT WRITE ON THIS PAGE



[BLANK PAGE]

DO NOT WRITE ON THIS PAGE



\* X 7 3 5 7 7 0 1 2 7 \*

[BLANK PAGE]

DO NOT WRITE ON THIS PAGE

*Acknowledgement of copyright*

- Question 2 VTT Studio/shutterstock.com  
APTX4869/shutterstock.com
- Question 3 (c) Mark Nazh/shutterstock.com
- Question 3 (g) Elegant Solution/shutterstock.com
- Question 4 (a)(v) Bardocz Peter/shutterstock.com
- Question 4 (b) Franck Boston/shutterstock.com
- Question 5 (a) Droidworker/shutterstock.com
- Question 5 (b) TatyanaTVK/shutterstock.com
- Question 5 (d) pedrosala/shutterstock.com
- Question 5 (e) viewgene/shutterstock.com



\* X 7 3 5 7 7 0 1 2 8 \*



National  
Qualifications  
2019

**X735/77/11**

**Graphic Communication  
Supplementary sheets**

TUESDAY, 21 MAY

1:00 PM – 3:00 PM

Supplementary sheets for use with questions 1 and 3.



\* X 7 3 5 7 7 1 1 \*

### Glass Container

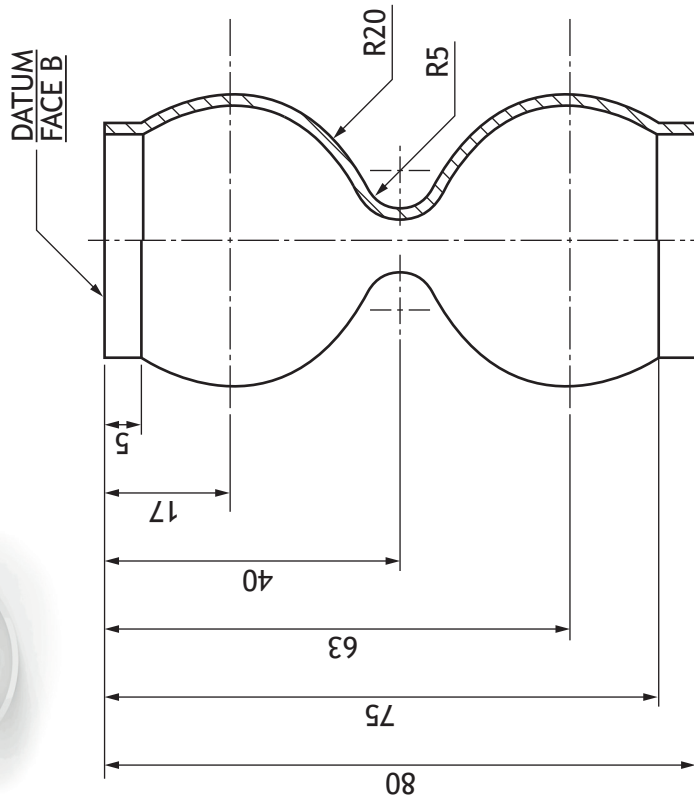
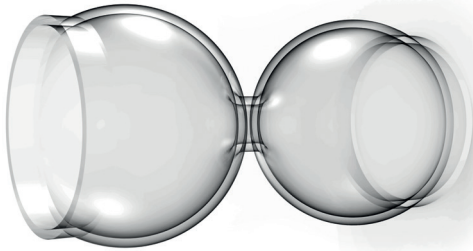
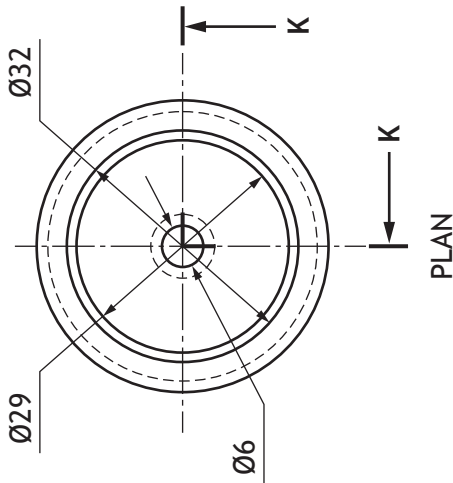

HALF SECTION  
ELEVATION K-K

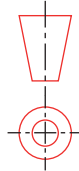

### Supporting Leg

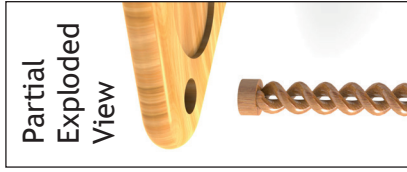

Enlarged View E  
Supporting Leg Detail  
Scale 5:1

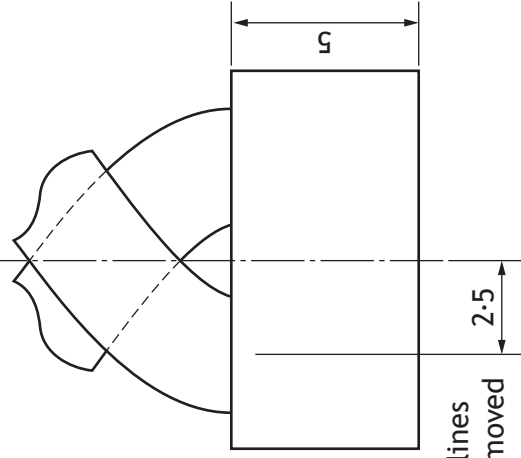

Some centre lines have been removed for clarity

Enlarged View F  
Supporting Leg Detail  
Scale 2:1

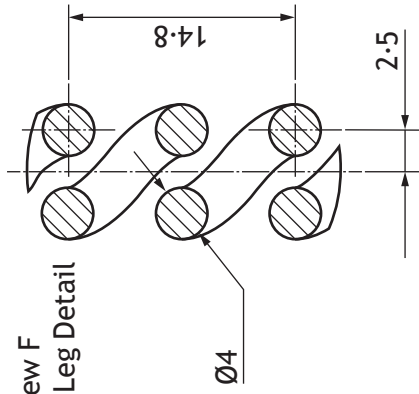

TOLERANCE A

Ø10±0.05

Ø9±0.05

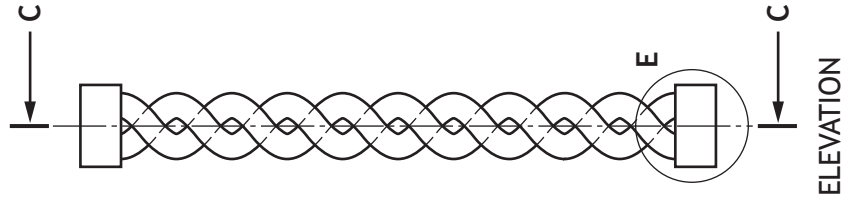
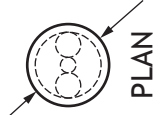

SECTIONAL END  
ELEVATION C-C

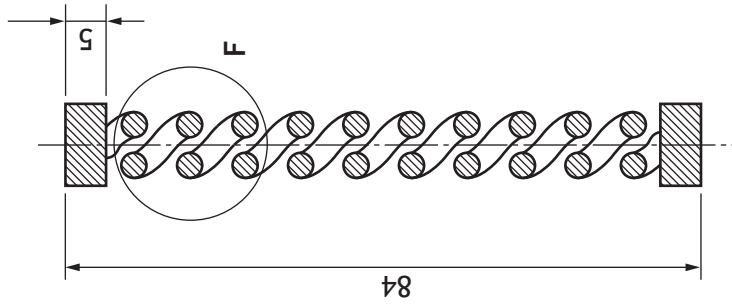

Egg Timer Part Drawings	Advanced Higher Graphic Communication	Scale: 1:1
Drawing Number 1	All dimensions in mm	Date: 10/10/2018
	Tolerance ± 0.1	

2000

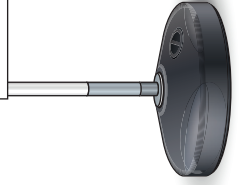
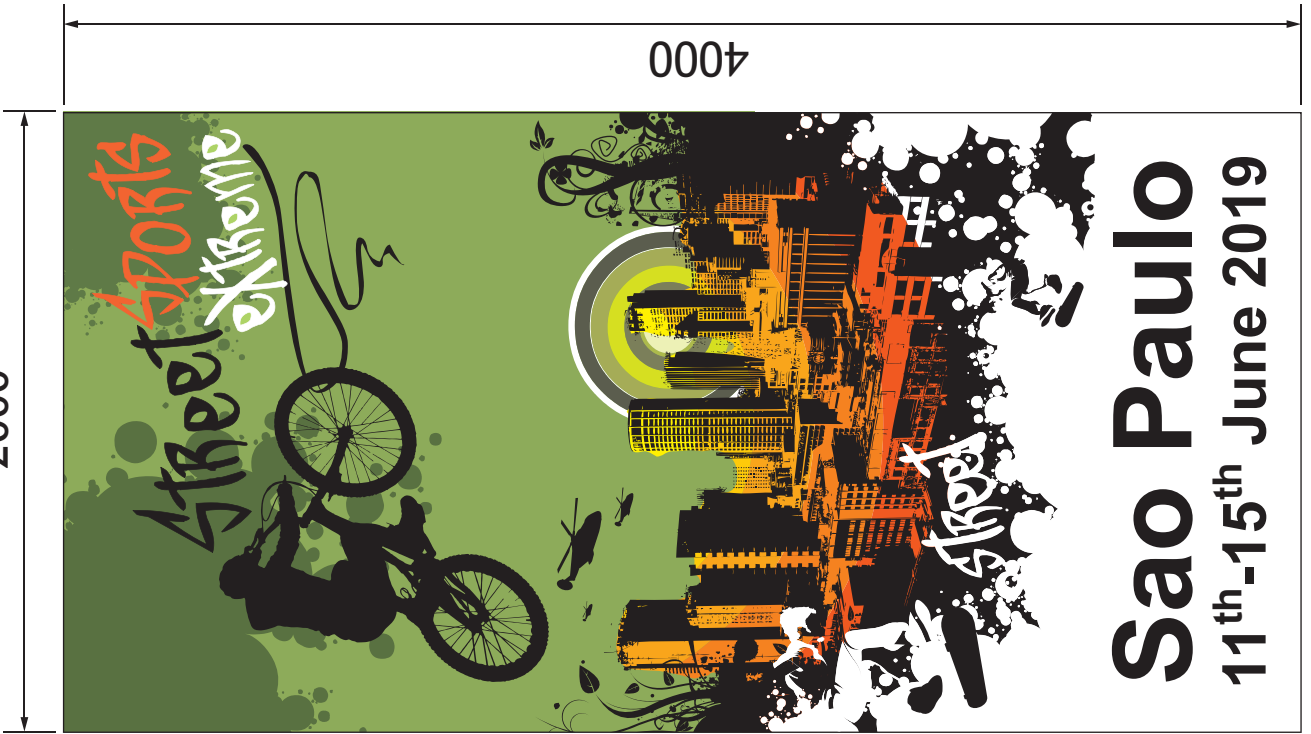

[BLANK PAGE]

DO NOT WRITE ON THIS PAGE

*Acknowledgement of copyright*

Question 3      filip Robert/shutterstock.com

Denis Semenchenko/shutterstock.com